

**MATERIALS**

PART NO.	A99341-031	REV	ECO	DATE	APP
		A	104858	09-25-18	HV

**HOUSING:**  
ALUMINUM 6061, NICKEL PLATE  
(500 MICROINCHES MINIMUM) PER  
SAE-AMS-2404

**INSULATOR:**  
LIQUID CRYSTAL POLYMER (LCP)  
PER ASTM D5138

**CONTACT:**  
COPPER ALLOY PER MIL-DTL-  
83513, GOLD PLATED PER ASTM  
B488, (HARD GOLD) TYPE II CODE  
C CLASS 1.27

**WIRE:**  
NEMA HP3 TYPE E, COLOR CODED  
IAW MIL-STD-681, SYSTEM 1,  
USING TEN SOLID REPEATING  
COLORS

**INTERFACIAL SEAL:**  
SILICONE RUBBER PER A-A-59588

**HARDWARE:**  
AVAILABLE UPON REQUEST

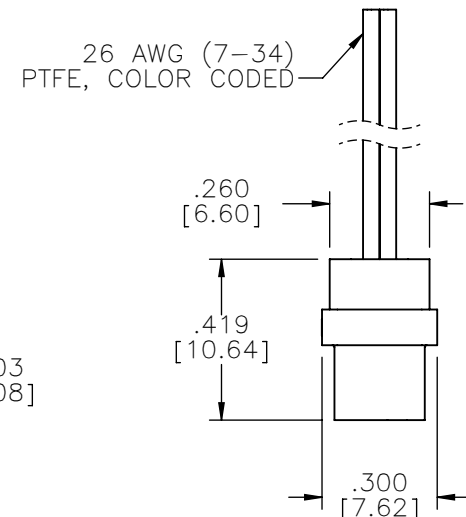
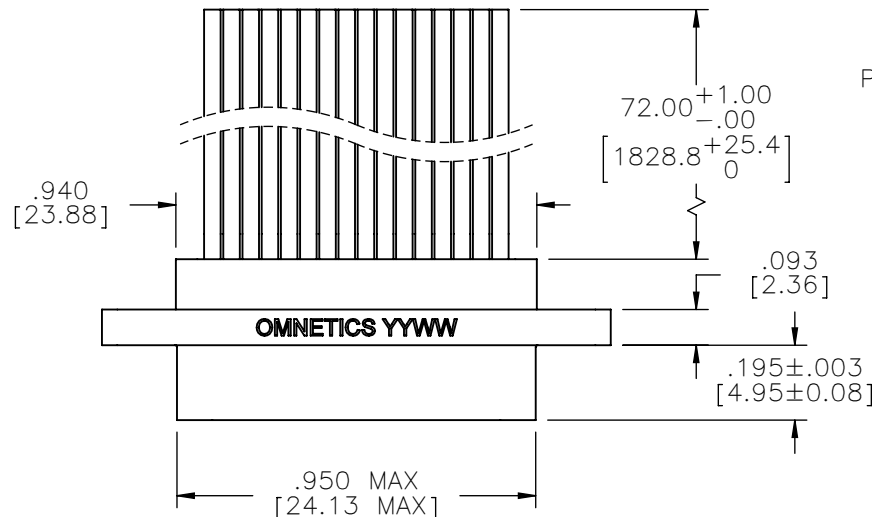

SOCKET #	COLOR
1, 11, 21, 31	BLACK
2, 12, 22	BROWN
3, 13, 23	RED
4, 14, 24	ORANGE
5, 15, 25	YELLOW
6, 16, 26	GREEN
7, 17, 27	BLUE
8, 18, 28	VIOLET
9, 19, 29	GRAY
10, 20, 30	WHITE

INTERNAL USE ONLY  
USE MFG LOADING  
PROCEDURE MMDS-031

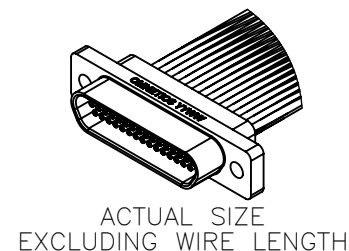
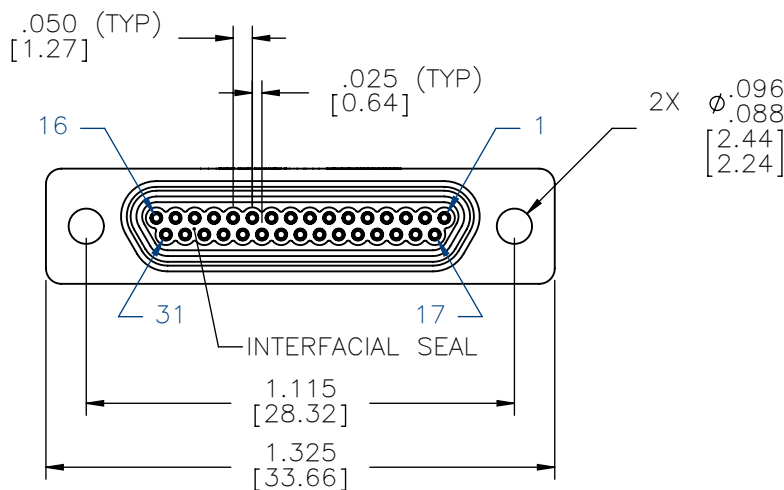

**RoHS**

**NOTE:**

DIMENSIONS IN [ ] ARE IN  
MILLIMETERS UNLESS  
OTHERWISE NOTED AND ARE  
FOR REFERENCE ONLY

MMS SLDW	THIRD ANGLE
	-TOLERANCES-
	UNLESS OTHERWISE NOTED
	DIMENSIONS IN INCHES
2	PL DEC ± .01
3	PL DEC ± .005
4	PL DEC ± .0005
	ANGLES ± 1°

THIS DRAWING CONTAINS CONFIDENTIAL AND PROPRIETARY INFORMATION WHICH IS THE PROPERTY OF OMNETICS CONNECTOR CORP. THIS DOCUMENT MAY NOT, IN WHOLE OR IN PART, BE DUPLICATED, OR DISCLOSED FOR ANY PURPOSE, WITHOUT WRITTEN PERMISSION FROM OMNETICS CONNECTOR CORP.	
DFTM. STN	DATE
CHK'D.	DATE
APP'D.	DATE
09-20-18	
TITLE: (31) SOCKET FEMALE MICRO-D CONNECTOR	

**OMNETICS**  
CONNECTOR CORPORATION  
7260 COMMERCE CIRCLE EAST  
MINNEAPOLIS, MN 55432  
WWW.OMNETICS.COM

CAGE CODE	61873
DWG NO.	A99341-031
SHEET 1 OF 1	REV A
SCALE:	2:1