

MATERIALS

HOUSING:
ALUMINUM 6061, NICKEL PLATE
(500 MICRONS MINIMUM) PER
SAE-AMS-2404

INSULATOR:
LIQUID CRYSTAL POLYMER (LCP)
PER ASTM D5138

CONTACT:
COPPER ALLOY PER MIL-DTL-
83513, GOLD PLATED PER ASTM
B488, (HARD GOLD) TYPE II CODE
C CLASS 1.27

WIRE:
NEMA HP3 TYPE E, COLOR CODED
IAW MIL-STD-681, SYSTEM 1,
USING TEN SOLID REPEATING
COLORS

INTERFACIAL SEAL:
SILICONE RUBBER PER A-A-59588

HARDWARE:
AVAILABLE UPON REQUEST

SOCKET #	COLOR
1, 11, 21	BLACK
2, 12, 22	BROWN
3, 13, 23	RED
4, 14, 24	ORANGE
5, 15, 25	YELLOW
6, 16	GREEN
7, 17	BLUE
8, 18	VIOLET
9, 19	GRAY
10, 20	WHITE

INTERNAL USE ONLY
USE MFG LOADING
PROCEDURE MMDS-025

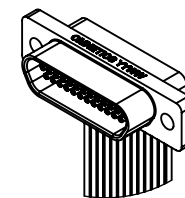
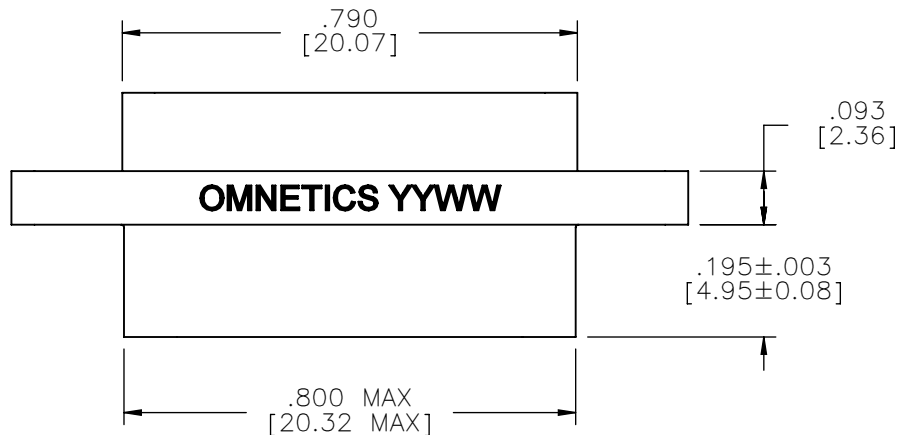

ACTUAL SIZE
EXCLUDING WIRE LENGTH

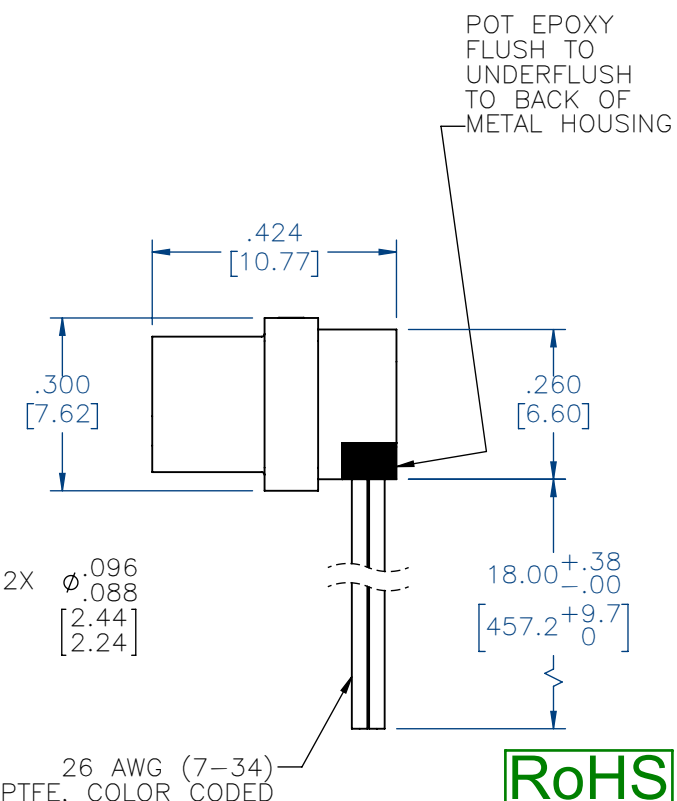
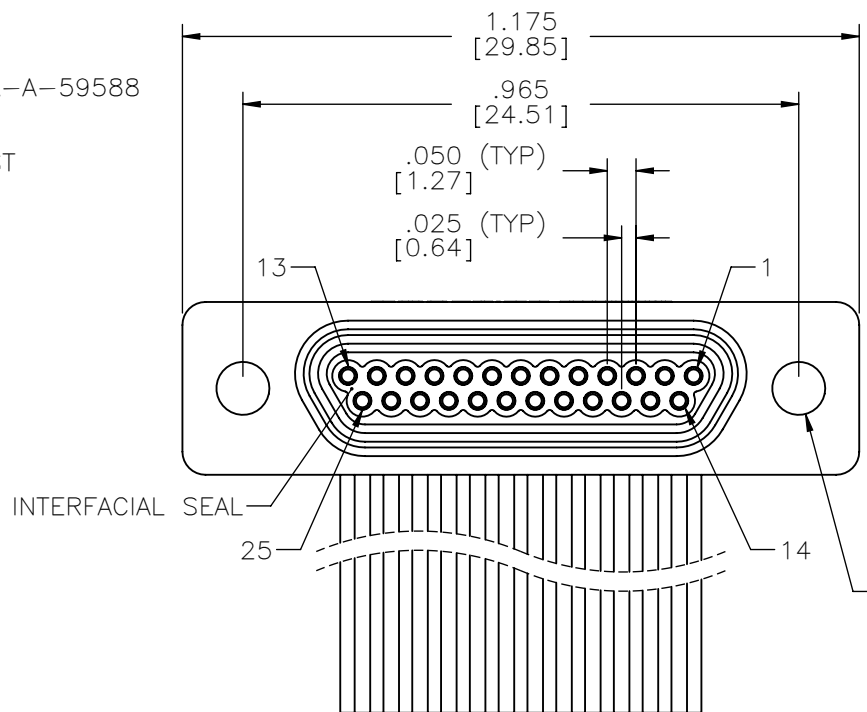

NOTE:

DIMENSIONS IN [] ARE IN
MILLIMETERS UNLESS
OTHERWISE NOTED AND ARE
FOR REFERENCE ONLY

MMDS SMDW	THIRD ANGLE
	-TOLERANCES-
	UNLESS OTHERWISE NOTED
	DIMENSIONS IN INCHES
MCTS SLDW	2 PL DEC± .01
	3 PL DEC± .005
	4 PL DEC± .0005
	ANGLES ± 1°

THIS DRAWING CONTAINS CONFIDENTIAL AND PROPRIETARY INFORMATION WHICH IS THE PROPERTY OF OMNETICS CONNECTOR CORP. THIS DOCUMENT MAY NOT, IN WHOLE OR IN PART, BE DUPLICATED, OR DISCLOSED FOR ANY PURPOSE, WITHOUT WRITTEN PERMISSION FROM OMNETICS CONNECTOR CORP.

TITLE:
DFTM. ERB
DATE
01-11-17

(25) SOCKET FEMALE
MICRO-D CONNECTOR

OMNETICS
CONNECTOR CORPORATION
8840 EVERGREEN BLVD.
MINNEAPOLIS, MN 55433
WWW.OMNETICS.COM

DWG NO.	CAGE CODE	61873
A99308-025		
SHEET	SCALE: 3:1	REV B
1 OF 1		