

MATERIALS & SPECIFICATIONS

PART NO.	A50016-105	REV	ECO	DATE	APP
		A	109678	01-24-23	BAS

HOUSING:
ALUMINUM 6061, NICKEL PLATE
(500 MICRONS MINIMUM) PER
SAE-AMS-2404

INSULATOR:
THERMOPLASTIC PER MIL-M-24519
OR ASTM 5138

CONTACT:
COPPER ALLOY PER MIL-DTL-
32139. GOLD PLATED PER ASTM
B488, (HARD GOLD) TYPE II CODE
C, CLASS 1.27

TERMINATION:
SOLDER COATED WITH SN63A PER
J-STD-006

HARDWARE:
303 STAINLESS STEEL PER ASTM
A582

CURRENT RATING:
1 AMP MAX PER MIL-DTL-32139

CONTACT RESISTANCE:
71 MILLIOHM MAX

PERFORMANCE:
PRODUCT FAMILY TESTED TO AND
PASSED THE PERFORMANCE
SPECIFICATIONS OF TABLE VIII OF
MIL-DTL-32139



ACTUAL SIZE

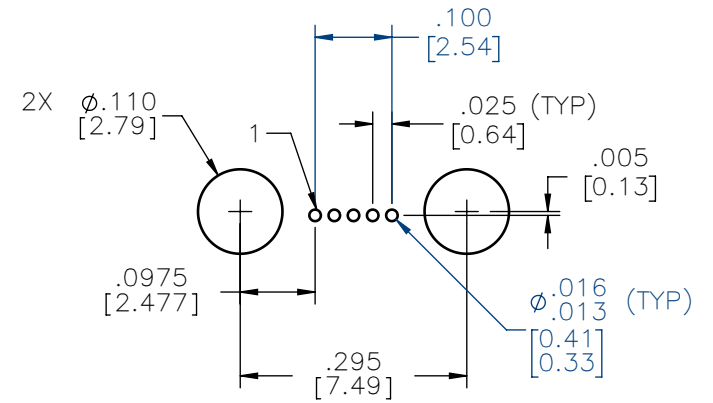
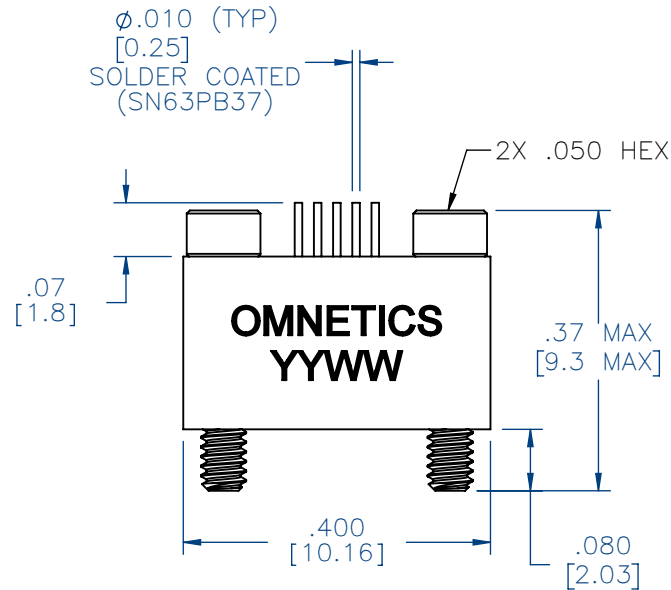

SUGGESTED HOLE PATTERN

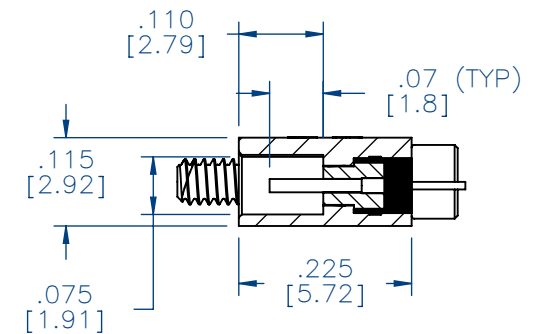
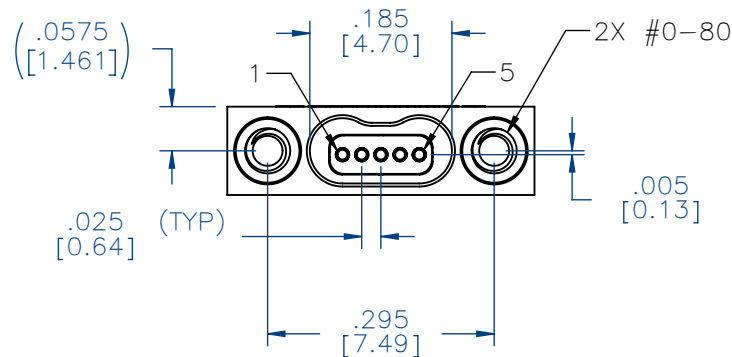

NOTES:

1. DIMENSIONS IN [] ARE IN MILLIMETERS UNLESS OTHERWISE NOTED AND ARE FOR REFERENCE ONLY

MBS	THIRD ANGLE ϕ \triangleleft
	-TOLERANCES-
SLDW	UNLESS OTHERWISE NOTED
	DIMENSIONS IN INCHES
	2 PL DEC \pm .01
	3 PL DEC \pm .005
	4 PL DEC \pm .0005
	ANGLES \pm 1°

THIS DRAWING CONTAINS CONFIDENTIAL AND PROPRIETARY INFORMATION WHICH IS THE PROPERTY OF OMNETICS CONNECTOR CORP. THIS DOCUMENT MAY NOT, IN WHOLE OR IN PART, BE DUPLICATED, OR DISCLOSED FOR ANY PURPOSE, WITHOUT WRITTEN PERMISSION FROM OMNETICS CONNECTOR CORP.

TITLE:	(5) SOCKET FEMALE
DFTM. DWP	BI-LOBE® CONNECTOR
DATE	W/JACKSCREWS
11-04-22	

OMNETICS
CONNECTOR CORPORATION
8840 EVERGREEN BLVD.
MINNEAPOLIS, MN 55433
WWW.OMNETICS.COM

DWG NO.	CAGE CODE 61873
A50016-105	
SHEET 1 OF 1	SCALE: 4:1
	REV A