

PART NO.	A42632-037	REV	ECO	DATE	APP
		A	106512	06-15-2020	TLM

PIN #	COLOR
1, 11, 21, 31	BLACK
2, 12, 22, 32	BROWN
3, 13, 23, 33	RED
4, 14, 24, 34	ORANGE
5, 15, 25, 35	YELLOW
6, 16, 26, 36	GREEN
7, 17, 27, 37	BLUE
8, 18, 28	VIOLET
9, 19, 29	GRAY
10, 20, 30	WHITE

INTERNAL USE ONLY
 USE MFG LOADING
 PROCEDURE A28000-037
 (BOTH CONNECTORS)

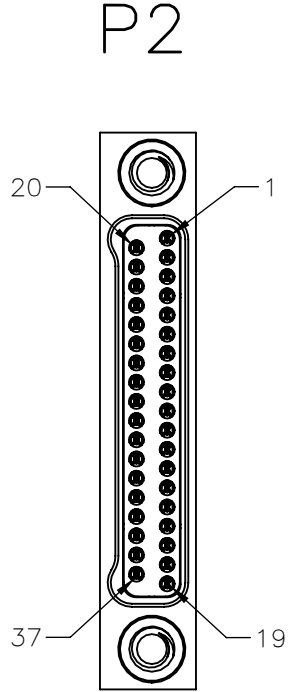
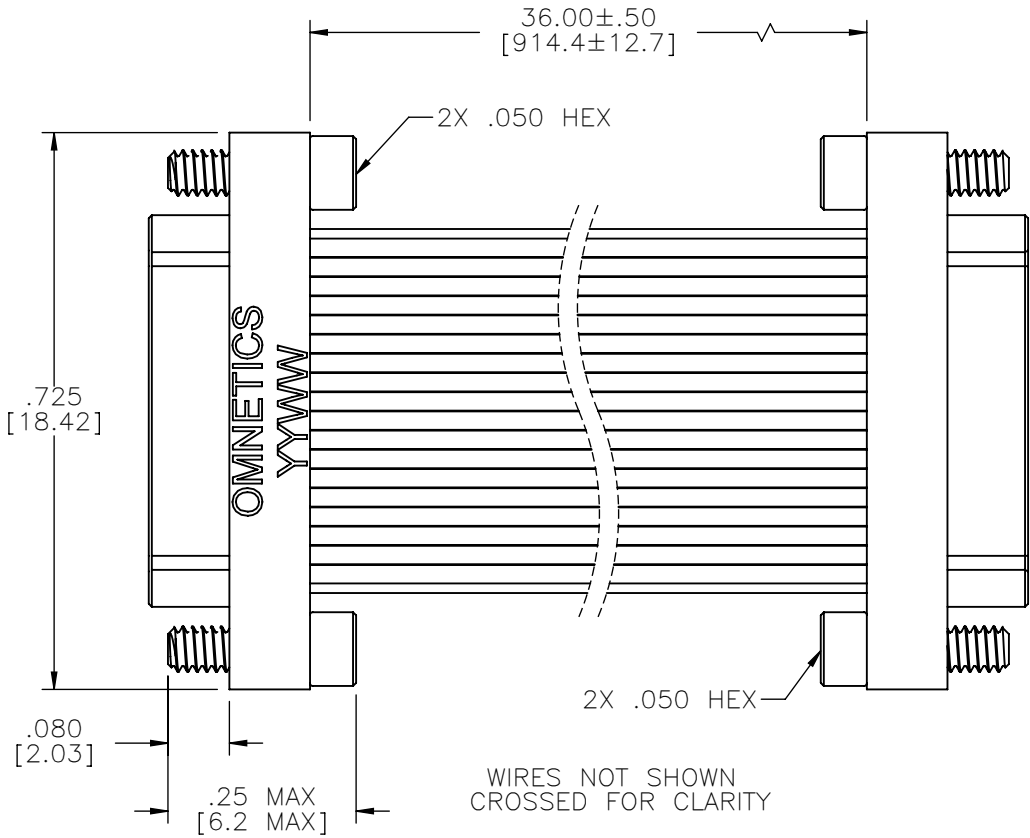
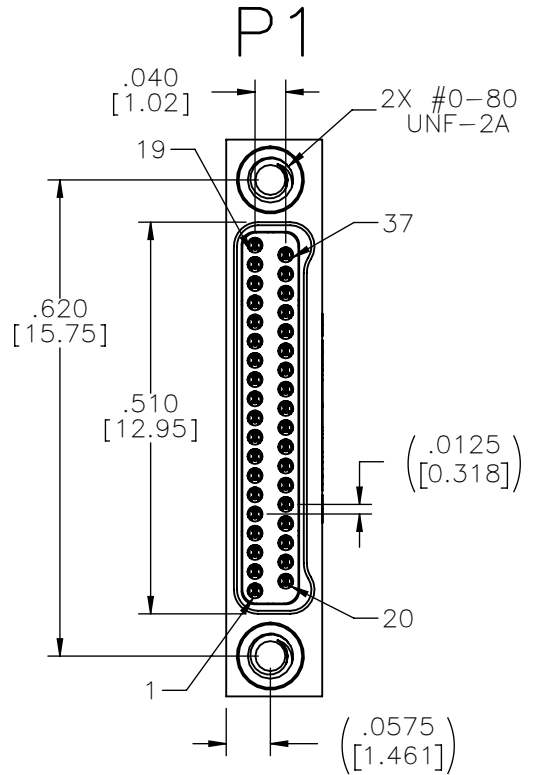
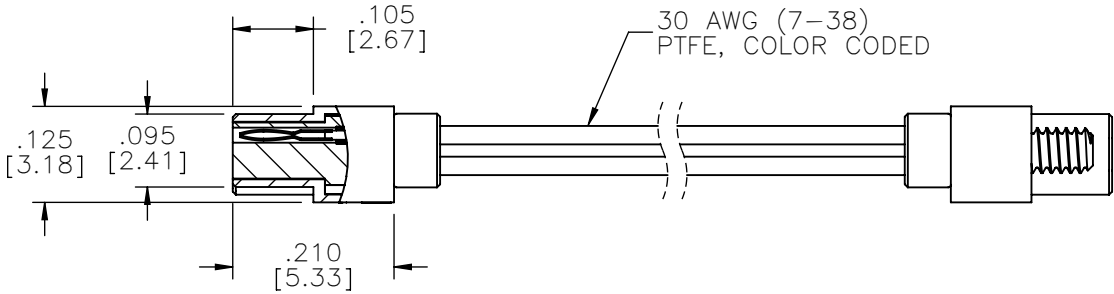

NOTES:
 DIMENSIONS APPLY TO BOTH CONNECTORS

DIMENSIONS IN [] ARE IN MILLIMETERS UNLESS OTHERWISE NOTED AND ARE FOR REFERENCE ONLY

JUM	THIRD ANGLE
	-TOLERANCES-
	UNLESS OTHERWISE NOTED
	DIMENSIONS IN INCHES
MCTS	2 PL DEC± .01
	3 PL DEC± .005
	4 PL DEC± .0005
	ANGLES ± 1°

THIS DRAWING CONTAINS CONFIDENTIAL AND PROPRIETARY INFORMATION WHICH IS THE PROPERTY OF OMNETICS CONNECTOR CORP. THIS DOCUMENT MAY NOT, IN WHOLE OR IN PART, BE DUPLICATED, OR DISCLOSED FOR ANY PURPOSE, WITHOUT WRITTEN PERMISSION FROM OMNETICS CONNECTOR CORP.	
DFTM. HV	DATE 06-08-20
CHK'D.	DATE
APP'D.	DATE

TITLE:
 (37) LINE MALE
 Bi-Lobe® JUMPER
 ASSEMBLY

WIRES NOT SHOWN
 CROSSED FOR CLARITY

OMNETICS
 CONNECTOR CORPORATION
 7260 COMMERCE CIRCLE EAST
 MINNEAPOLIS, MN 55432
 WWW.OMNETICS.COM

CAGE CODE 61873
DWG NO. A42632-037
SHEET 1 OF 2
SCALE: 4:1
REV A

PART NO.	A42632-037	REV	ECO	DATE	APP
		A	106512	06-15-2020	TLM

MATERIALS & SPECIFICATIONS

HOUSING:
ALUMINUM 6061, NICKEL PLATE (500 MICROINCHES MINIMUM)
PER SAE-AMS-2404

INSULATOR:
LIQUID CRYSTAL POLYMER (LCP) PER ASTM D5138

CONTACT:
BERYLLIUM COPPER PER ASTM B194, C17200, GOLD PLATED
PER ASTM B488, (HARD GOLD) TYPE II CODE C, CLASS 1.27



WIRE:
NEMA HP3 TYPE ET, COLOR CODED IAW MIL-STD-681,
SYSTEM 1, USING TEN SOLID REPEATING COLORS

HARDWARE:
303 STAINLESS STEEL PER ASTM A582

CURRENT RATING:
1 AMP MAX PER MIL-DTL-32139

CONTACT RESISTANCE:
71 MILLIOHM MAX (71mV DROP MAX) @ 1.0 AMPS PER MIL-
DTL-32139

PERFORMANCE:
PRODUCT FAMILY TESTED TO AND PASSED THE PERFORMANCE
SPECIFICATIONS OF TABLE VIII OF
MIL-DTL-32139

JUM	THIRD ANGLE 	THIS DRAWING CONTAINS CONFIDENTIAL AND PROPRIETARY INFORMATION WHICH IS THE PROPERTY OF OMNETICS CONNECTOR CORP. THIS DOCUMENT MAY NOT, IN WHOLE OR IN PART, BE DUPLICATED, OR DISCLOSED FOR ANY PURPOSE, WITHOUT WRITTEN PERMISSION FROM OMNETICS CONNECTOR CORP.		 CONNECTOR CORPORATION 7260 COMMERCE CIRCLE EAST MINNEAPOLIS, MN 55432 WWW.OMNETICS.COM	CAGE CODE 61873
	SLDW	-TOLERANCES- UNLESS OTHERWISE NOTED DIMENSIONS IN INCHES	DFTM. HV DATE 06-08-20		TITLE: (37) LINE MALE Bi-Lobe® JUMPER ASSEMBLY
	2 PL DEC± .01 3 PL DEC± .005 4 PL DEC± .0005 ANGLES ± 1°	CHK'D. DATE	APP'D. DATE		SHEET 2 OF 2 SCALE: 4:1
					REV A