

PIN #	COLOR
1, 11, 21	BLACK
2, 12, 22	BROWN
3, 13, 23	RED
4, 14, 24	ORANGE
5, 15, 25	YELLOW
6, 16	GREEN
7, 17	BLUE
8, 18	VIOLET
9, 19	GRAY
10, 20	WHITE

INTERNAL USE ONLY
USE MFG LOADING
PROCEDURE A28000-025
(BOTH CONNECTORS)

PART NO.	A42632-025	REV	ECO	DATE	APP
		A	106517	06-22-2020	TLM

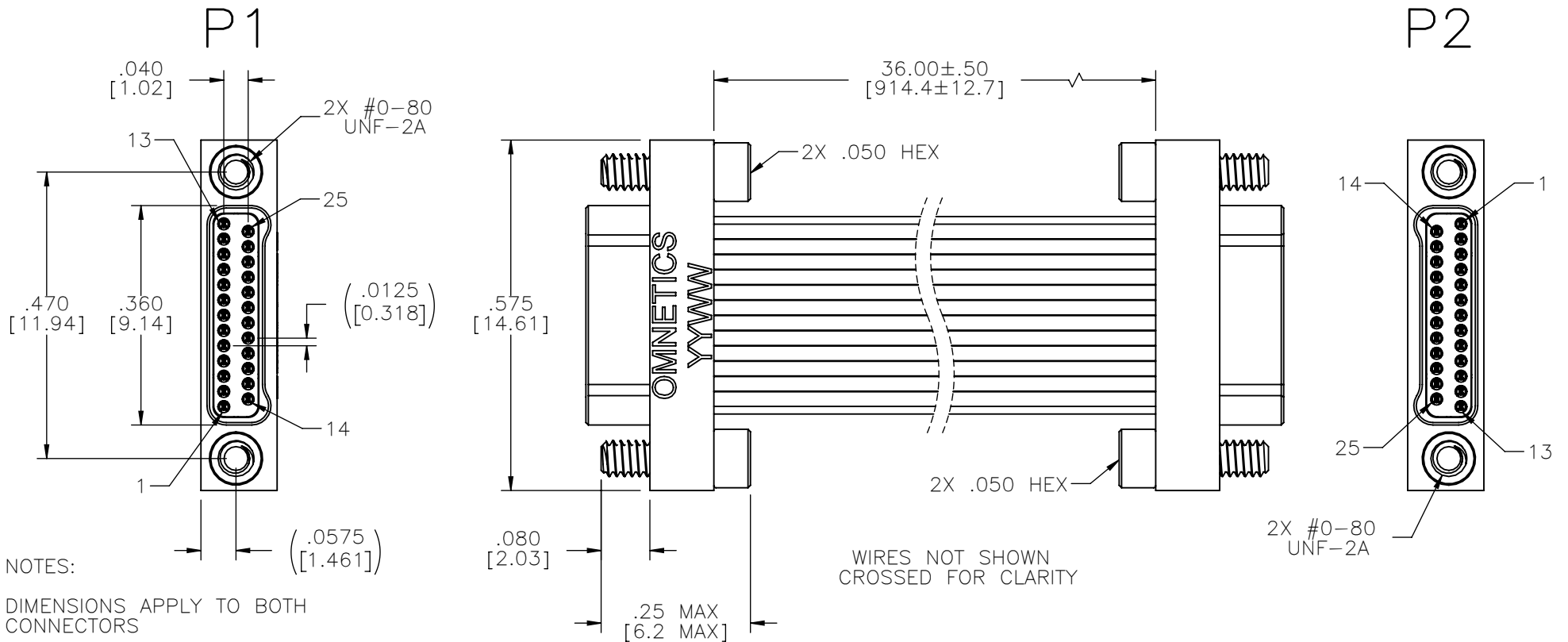
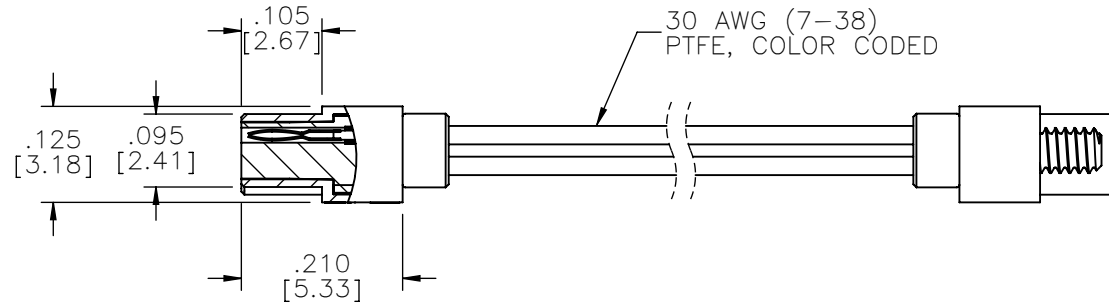

NOTES:

DIMENSIONS APPLY TO BOTH CONNECTORS

WIRE CONNECTORS 1 TO 1, 2 TO 2, ETC.

DIMENSIONS IN [] ARE IN MILLIMETERS UNLESS OTHERWISE NOTED AND ARE FOR REFERENCE ONLY

THIRD ANGLE	
JUM	- TOLERANCES -
	UNLESS OTHERWISE NOTED
	DIMENSIONS IN INCHES
2	PL DEC ± .01
3	PL DEC ± .005
4	PL DEC ± .0005
	ANGLES ± 1°

THIS DRAWING CONTAINS CONFIDENTIAL AND PROPRIETARY INFORMATION WHICH IS THE PROPERTY OF OMNETICS CONNECTOR CORP. THIS DOCUMENT MAY NOT, IN WHOLE OR IN PART, BE DUPLICATED, OR DISCLOSED FOR ANY PURPOSE, WITHOUT WRITTEN PERMISSION FROM OMNETICS CONNECTOR CORP.	
DFTM. EDG	DATE 06-10-20
CHK'D.	DATE
APP'D.	DATE

TITLE:
(25) LINE MALE
Bi-Lobe® JUMPER
ASSEMBLY

OMNETICS
CONNECTOR CORPORATION
7260 COMMERCE CIRCLE EAST
MINNEAPOLIS, MN 55432
WWW.OMNETICS.COM

CAGE CODE 61873
DWG NO. A42632-025
SHEET 1 OF 2
SCALE: 4:1
REV A

PART NO.	A42632-025	REV	ECO	DATE	APP
		A	106517	06-22-2020	TLM

MATERIALS & SPECIFICATIONS

HOUSING:
ALUMINUM 6061, NICKEL PLATE (500 MICROINCHES MINIMUM)
PER SAE-AMS-2404

INSULATOR:
LIQUID CRYSTAL POLYMER (LCP) PER ASTM D5138

CONTACT:
BERYLLIUM COPPER PER ASTM B194, C17200, GOLD PLATED
PER ASTM B488, (HARD GOLD) TYPE II CODE C, CLASS 1.27



WIRE:
NEMA HP3 TYPE ET, COLOR CODED IAW MIL-STD-681,
SYSTEM 1, USING TEN SOLID REPEATING COLORS

HARDWARE:
303 STAINLESS STEEL PER ASTM A582

CURRENT RATING:
1 AMP MAX PER MIL-DTL-32139

CONTACT RESISTANCE:
71 MILLIOHM MAX (71mV DROP MAX) @ 1.0 AMPS PER MIL-
DTL-32139

PERFORMANCE:
PRODUCT FAMILY TESTED TO AND PASSED THE PERFORMANCE
SPECIFICATIONS OF TABLE VIII OF
MIL-DTL-32139

MCTS	JUM	THIRD ANGLE 	THIS DRAWING CONTAINS CONFIDENTIAL AND PROPRIETARY INFORMATION WHICH IS THE PROPERTY OF OMNETICS CONNECTOR CORP. THIS DOCUMENT MAY NOT, IN WHOLE OR IN PART, BE DUPLICATED, OR DISCLOSED FOR ANY PURPOSE, WITHOUT WRITTEN PERMISSION FROM OMNETICS CONNECTOR CORP.		 CONNECTOR CORPORATION 7260 COMMERCE CIRCLE EAST MINNEAPOLIS, MN 55432 WWW.OMNETICS.COM	CAGE CODE 61873
		-TOLERANCES- UNLESS OTHERWISE NOTED	DFTM. EDG	DATE 06-10-20		TITLE: (25) LINE MALE Bi-Lobe® JUMPER ASSEMBLY
SLDW		DIMENSIONS IN INCHES	CHK'D.	DATE		SHEET 2 OF 2
		2 PL DEC± .01 3 PL DEC± .005 4 PL DEC± .0005 ANGLES ± 1°	APP'D.	DATE		REV A
						SCALE: 4:1