

PART NO.	A42629-051	REV	ECO	DATE	APP
		A	101463	04-06-15	BCV

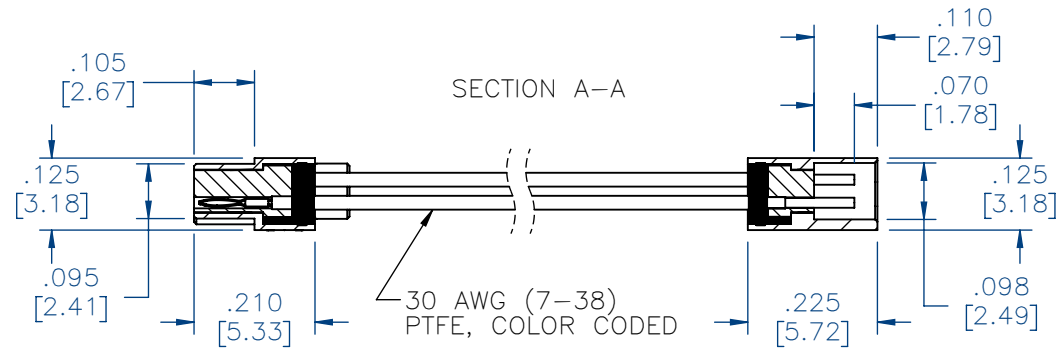

INTERNAL USE ONLY
USE MFG LOADING
PROCEDURE A28000-051

INTERNAL USE ONLY
USE MFG LOADING
PROCEDURE A29000-051

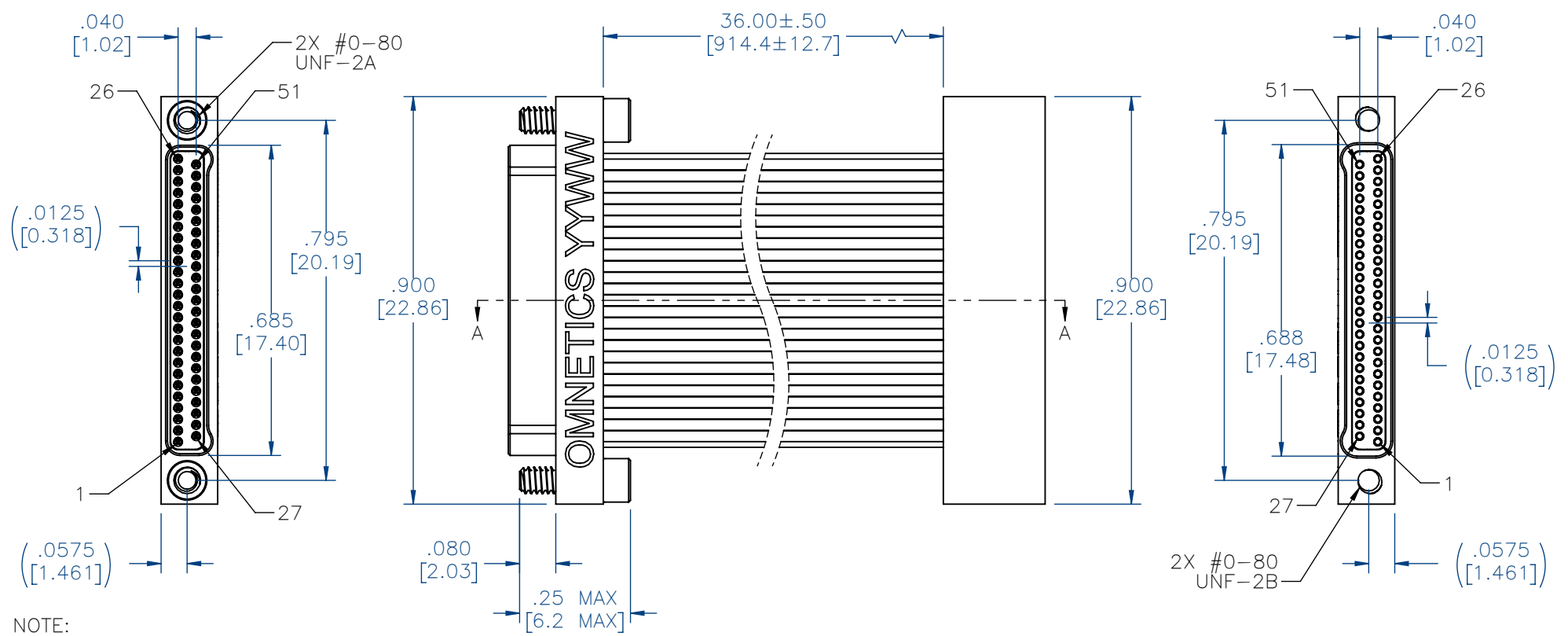

NOTE:
WIRE CONNECTOR 1 TO 1,
2 TO 2, 3 TO 3, ETC.

DIMENSIONS IN [] ARE IN
MILLIMETERS UNLESS
OTHERWISE NOTED AND ARE
FOR REFERENCE ONLY

JUM	THIRD ANGLE
	-TOLERANCES-
	UNLESS OTHERWISE NOTED
	DIMENSIONS IN INCHES
SLDW	2 PL DEC± .01
	3 PL DEC± .005
	4 PL DEC± .0005
	ANGLES ± 1°

THIS DRAWING CONTAINS CONFIDENTIAL AND PROPRIETARY INFORMATION WHICH IS THE PROPERTY OF OMNETICS CONNECTOR CORP. THIS DOCUMENT MAY NOT, IN WHOLE OR IN PART, BE DUPLICATED, OR DISCLOSED FOR ANY PURPOSE, WITHOUT WRITTEN PERMISSION FROM OMNETICS CONNECTOR CORP.	
DFTM. TLM	DATE 03-25-15
CHK'D.	DATE
APP'D.	DATE
TITLE: (51) LINE MALE/FEMALE Bi-Lobe® CONNECTOR ASSEMBLY	

OMNETICS
CONNECTOR CORPORATION
7260 COMMERCE CIRCLE EAST
MINNEAPOLIS, MN 55432
WWW.OMNETICS.COM

CAGE CODE	61873
DWG NO.	A42629-051
SHEET 1 OF 2	REV A
SCALE:	3:1

PART NO.	A42629-051	REV	ECO	DATE	APP
		A	101463	04-06-15	BCV

MATERIALS & SPECIFICATIONS

HOUSING:
ALUMINUM 6061-T6, NICKEL PLATE
PER SAE-AMS-2404.

INSULATOR:
LIQUID CRYSTAL POLYMER (LCP) PER
ASTM D5138

PIN:
BERYLLIUM COPPER PER ASTM B194,
C17200, GOLD PLATED PER ASTM
B488, (HARD GOLD) TYPE II CODE C,
CLASS 1.27

SOCKET:
COPPER ALLOY PER MIL-DTL-32139,
GOLD PLATED PER ASTM B488,
(HARD GOLD) TYPE II CODE C CLASS
1.27

WIRE:
NEMA HP3 TYPE ET, COLOR CODED
IAW MIL-STD-681, SYSTEM 1, USING
TEN SOLID REPEATING COLORS

HARDWARE:
303 STAINLESS STEEL PER ASTM 582

CURRENT RATING:
1 AMP MAX PER MIL-DTL-32139

CONTACT RESISTANCE:
71 MILLIOHM MAX (71mV DROP MAX)
@ 1.0 AMPS PER MIL-DTL-32139

PERFORMANCE:
PRODUCT FAMILY TESTED TO AND
PASSED THE PERFORMANCE
SPECIFICATIONS OF TABLE VIII OF
MIL-DTL-32139.

CONTACT #	COLOR
1, 11, 21, 31, 41, 51	BLACK
2, 12, 22, 32, 42	BROWN
3, 13, 23, 33, 43	RED
4, 14, 24, 34, 44	ORANGE
5, 15, 25, 35, 45	YELLOW
6, 16, 26, 36, 46	GREEN
7, 17, 27, 37, 47	BLUE
8, 18, 28, 38, 48	VIOLET
9, 19, 29, 39, 49	GRAY
10, 20, 30, 40, 50	WHITE

MGT'S	JUN	THIRD ANGLE 	THIS DRAWING CONTAINS CONFIDENTIAL AND PROPRIETARY INFORMATION WHICH IS THE PROPERTY OF OMNETICS CONNECTOR CORP. THIS DOCUMENT MAY NOT, IN WHOLE OR IN PART, BE DUPLICATED, OR DISCLOSED FOR ANY PURPOSE, WITHOUT WRITTEN PERMISSION FROM OMNETICS CONNECTOR CORP.		CAGE CODE 61873
		-TOLERANCES- UNLESS OTHERWISE NOTED	DFTM. TLM	DATE 03-25-15	
		DIMENSIONS IN INCHES	CHK'D.	DATE	SHEET 2 OF 2
		2 PL DEC± .01	APP'D.	DATE	REV A
		3 PL DEC± .005			SCALE: 3:1
		4 PL DEC± .0005			
		ANGLES ± 1°			



7260 COMMERCE CIRCLE EAST
MINNEAPOLIS, MN 55432
WWW.OMNETICS.COM