

PART NO.	A42629-015	REV	ECO	DATE	APP
		A	103857	10-10-17	TLM

POSITION #	COLOR
1, 11	BLACK
2, 12	BROWN
3, 13	RED
4, 14	ORANGE
5, 15	YELLOW
6	GREEN
7	BLUE
8	VIOLET
9	GRAY
10	WHITE

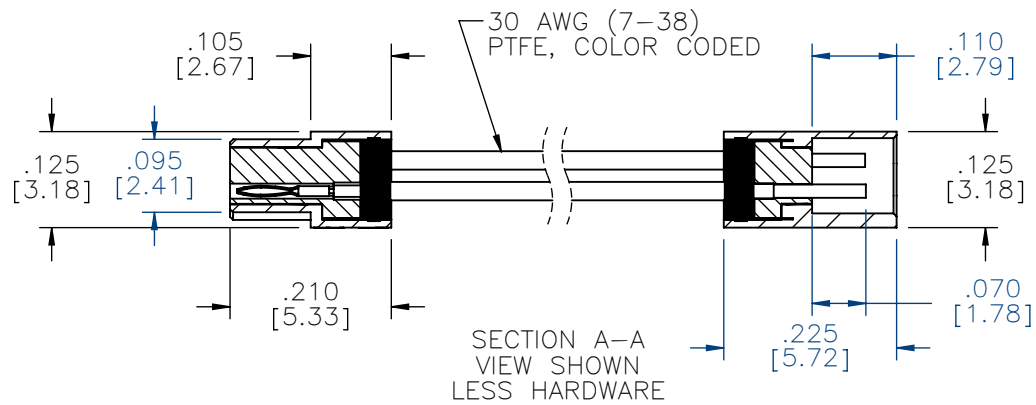

P1

P2

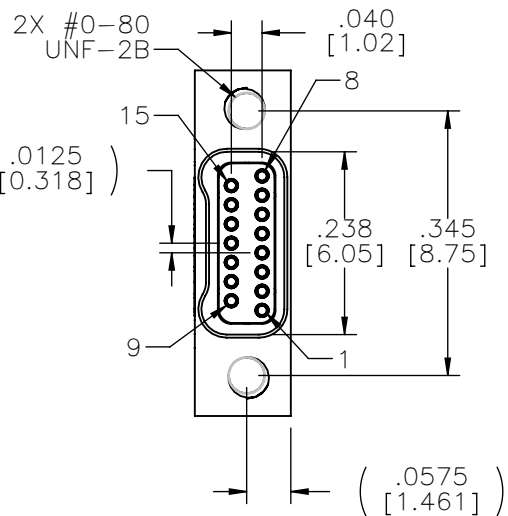
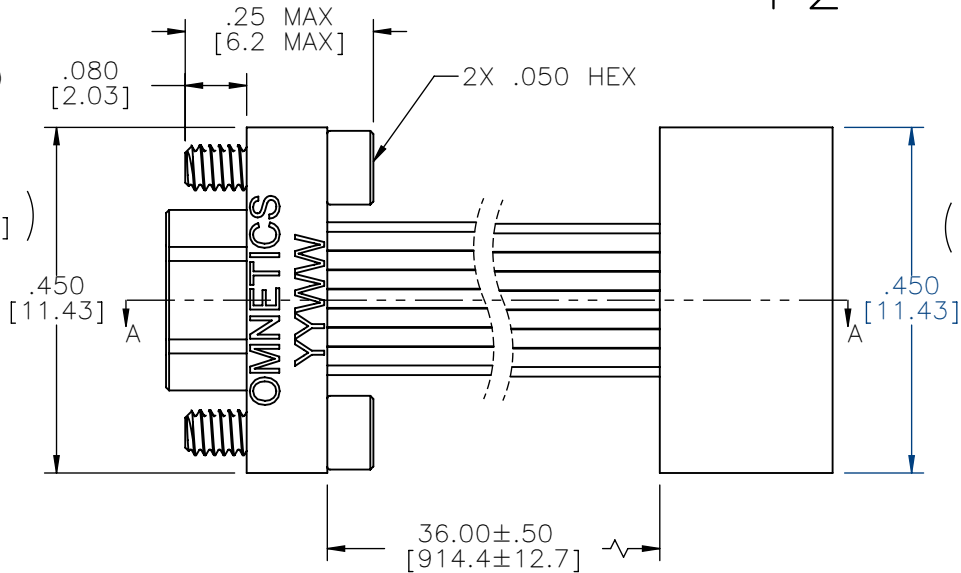
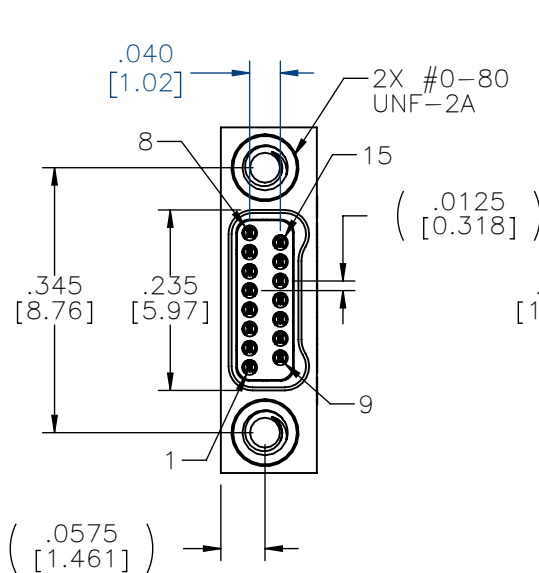

INTERNAL USE ONLY
USE MFG LOADING
PROCEDURE A28000-015

INTERNAL USE ONLY
USE MFG LOADING
PROCEDURE A29000-015

NOTES:
WIRE CONNECTOR 1 TO 1,
2 TO 2, 3 TO 3, ETC.

DIMENSIONS IN [] ARE IN
MILLIMETERS UNLESS
OTHERWISE NOTED AND ARE
FOR REFERENCE ONLY

REF: OMNETICS

JUM	THIRD ANGLE
	-TOLERANCES-
	UNLESS OTHERWISE NOTED
	DIMENSIONS IN INCHES
MCTS	2 PL DEC± .01
	3 PL DEC± .005
	4 PL DEC± .0005
	ANGLES ± 1°

THIS DRAWING CONTAINS CONFIDENTIAL AND PROPRIETARY INFORMATION WHICH IS THE PROPERTY OF OMNETICS CONNECTOR CORP. THIS DOCUMENT MAY NOT, IN WHOLE OR IN PART, BE DUPLICATED, OR DISCLOSED FOR ANY PURPOSE, WITHOUT WRITTEN PERMISSION FROM OMNETICS CONNECTOR CORP.	
DFTM. EDG	DATE 09-29-17
CHK'D.	DATE
APP'D.	DATE
TITLE: (15) LINE MALE/FEMALE Bi-Lobe® JUMPER ASSEMBLY	

OMNETICS
CONNECTOR CORPORATION
7260 COMMERCE CIRCLE EAST
MINNEAPOLIS, MN 55432
WWW.OMNETICS.COM

CAGE CODE	61873
DWG NO.	A42629-015
SHEET 1 OF 2	REV A
SCALE:	4:1

PART NO.	A42629-015	REV	ECO	DATE	APP
		A	103857	10-10-17	TLM

MATERIALS & SPECIFICATIONS

HOUSING:
ALUMINUM 6061, NICKEL PLATE (500 MICROINCHES MINIMUM) PER SAE-AMS-2404.

INSULATOR:
LIQUID CRYSTAL POLYMER (LCP) PER ASTM D5138

PIN:
BERYLLIUM COPPER PER ASTM B194, C17200, GOLD PLATED PER ASTM B488, (HARD GOLD) TYPE II CODE C, CLASS 1.27

SOCKET:
COPPER ALLOY PER MIL-DTL-32139, GOLD PLATED PER ASTM B488, (HARD GOLD) TYPE II CODE C CLASS 1.27

WIRE:
NEMA HP3 TYPE ET, COLOR CODED IAW MIL-STD-681, SYSTEM 1, USING TEN SOLID REPEATING COLORS



HARDWARE:
303 STAINLESS STEEL PER ASTM A582

CURRENT RATING:
1 AMP MAX PER MIL-DTL-32139

CONTACT RESISTANCE:
71 MILLIOHM MAX (71mV DROP MAX) @ 1.0 AMPS PER MIL-DTL-32139

PERFORMANCE:
PRODUCT FAMILY TESTED TO AND PASSED THE PERFORMANCE SPECIFICATIONS OF TABLE VIII OF MIL-DTL-32139.

REF: OMNETICS

JUM	THIRD ANGLE 	THIS DRAWING CONTAINS CONFIDENTIAL AND PROPRIETARY INFORMATION WHICH IS THE PROPERTY OF OMNETICS CONNECTOR CORP. THIS DOCUMENT MAY NOT, IN WHOLE OR IN PART, BE DUPLICATED, OR DISCLOSED FOR ANY PURPOSE, WITHOUT WRITTEN PERMISSION FROM OMNETICS CONNECTOR CORP.	DATE 09-29-17	TITLE: (15) LINE MALE/FEMALE Bi-Lobe® JUMPER ASSEMBLY	 OMNETICS CONNECTOR CORPORATION 7260 COMMERCE CIRCLE EAST MINNEAPOLIS, MN 55432 WWW.OMNETICS.COM	CAGE CODE 61873
	UNLESS OTHERWISE NOTED					DFTM. EDG
SLDW	DIMENSIONS IN INCHES		DATE			SHEET 2 OF 2
	2 PL DEC ± .01 3 PL DEC ± .005 4 PL DEC ± .0005 ANGLES ± 1°	CHK'D.	DATE			REV A
		APP'D.	DATE			SCALE: 4:1