

MATERIALS & SPECIFICATIONS

PART NO.	A29072-137	REV	ECO	DATE	APP
		A	104349	03-27-18	HV

HOUSING:
ALUMINUM 6061, NICKEL PLATE (500 MICROINCHES MINIMUM) PER SAE-AMS-2404

INSULATOR:
LIQUID CRYSTAL POLYMER (LCP) PER ASTM D5138

CONTACT:
COPPER ALLOY PER MIL-DTL-32139, GOLD PLATED PER ASTM B488, (HARD GOLD) TYPE II CODE C CLASS 1.27

WIRE:
NEMA HP3 TYPE ET, COLOR CODED IAW MIL-STD-681, SYSTEM 1, USING TEN SOLID REPEATING COLORS

HARDWARE:
303 STAINLESS STEEL PER ASTM A582

CURRENT RATING:
1 AMP MAX PER MIL-DTL-32139

CONTACT RESISTANCE:
71 MILLIOHM MAX (71mV DROP MAX) @ 1.0 AMPS PER MIL-DTL-32139

PERFORMANCE:
PRODUCT FAMILY TESTED TO AND PASSED THE PERFORMANCE SPECIFICATIONS OF TABLE VIII OF MIL-DTL-32139

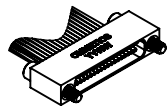

ACTUAL SIZE EXCLUDING WIRE LENGTH

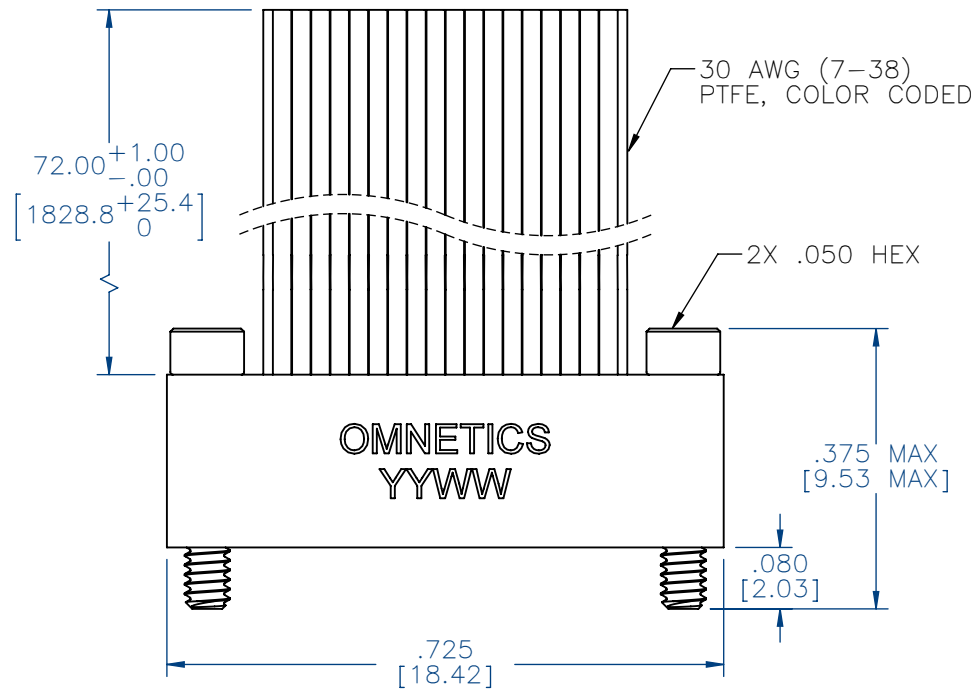

SOCKET #	COLOR
1, 11, 21, 31	BLACK
2, 12, 22, 32	BROWN
3, 13, 23, 33	RED
4, 14, 24, 34	ORANGE
5, 15, 25, 35	YELLOW
6, 16, 26, 36	GREEN
7, 17, 27, 37	BLUE
8, 18, 28	VIOLET
9, 19, 29	GRAY
10, 20, 30	WHITE

INTERNAL USE ONLY
USE MFG LOADING
PROCEDURE A29000-137

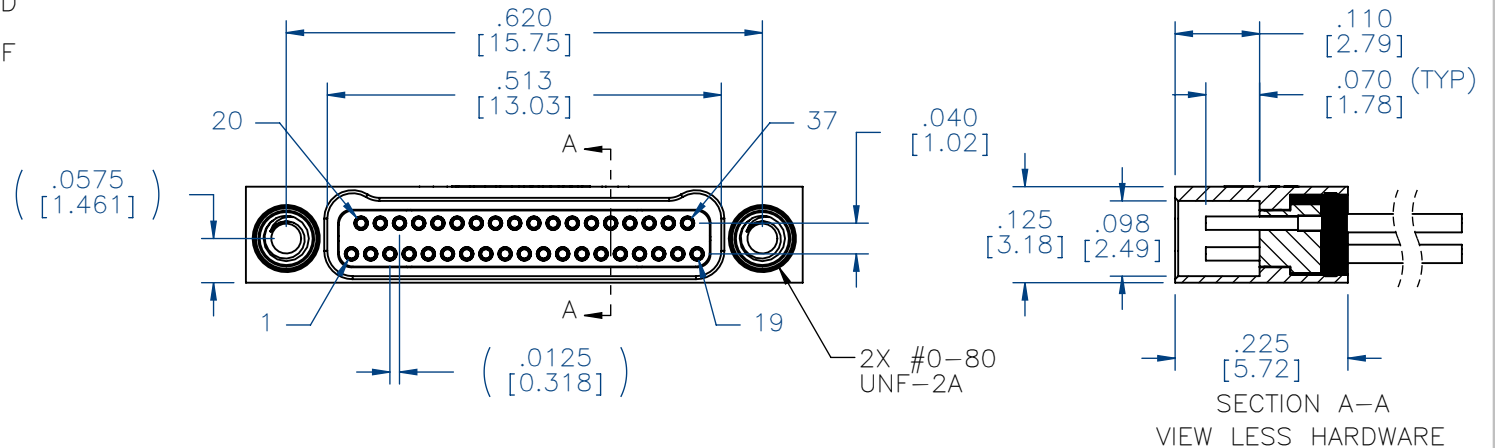

NOTE:

DIMENSIONS IN [] ARE IN MILLIMETERS UNLESS OTHERWISE NOTED AND ARE FOR REFERENCE ONLY

MGT'S	OSN/W	THIRD ANGLE
		- TOLERANCES -
		UNLESS OTHERWISE NOTED
		DIMENSIONS IN INCHES
2	PL DEC ± .01	
3	PL DEC ± .005	
4	PL DEC ± .0005	
		ANGLES ± 1°

THIS DRAWING CONTAINS CONFIDENTIAL AND PROPRIETARY INFORMATION WHICH IS THE PROPERTY OF OMNETICS CONNECTOR CORP. THIS DOCUMENT MAY NOT, IN WHOLE OR IN PART, BE DUPLICATED, OR DISCLOSED FOR ANY PURPOSE, WITHOUT WRITTEN PERMISSION FROM OMNETICS CONNECTOR CORP.	
DFTM. TLM	DATE 03-20-18
CHK'D.	DATE
APP'D.	DATE
TITLE: (37) SOCKET FEMALE Bi-Lobe® CONNECTOR	

OMNETICS
CONNECTOR CORPORATION
7260 COMMERCE CIRCLE EAST
MINNEAPOLIS, MN 55432
WWW.OMNETICS.COM

CAGE CODE 61873
DWG NO. A29072-137
SHEET 1 OF 1
SCALE: 4:1
REV A