

MATERIALS & SPECIFICATIONS

PART NO.	A29048-125	REV	ECO	DATE	APP
		A	99441	04-13-13	TLM

- HOUSING:**
ALUMINUM 6061-T6, NICKEL PLATE
PER SAE-AMS-2404
- INSULATOR:**
LIQUID CRYSTAL POLYMER (LCP) PER
ASTM D5138
- CONTACT:**
COPPER ALLOY PER MIL-DTL-32139,
GOLD PLATED PER ASTM B488,
(HARD GOLD) TYPE II CODE C CLASS
1.27
- WIRE:**
NEMA HP3 TYPE ET, COLOR CODED
IAW MIL-STD-681, SYSTEM 1, USING
TEN SOLID REPEATING COLORS
- HARDWARE:**
303 STAINLESS STEEL PER ASTM 582
- CURRENT RATING:**
1 AMP MAX PER MIL-DTL-32139
- CONTACT RESISTANCE:**
71 MILLIOHM MAX (71mV DROP MAX)
@ 1.0 AMPS PER MIL-DTL-32139
- PERFORMANCE:**
PRODUCT FAMILY TESTED TO AND
PASSED THE PERFORMANCE
SPECIFICATIONS OF TABLE VIII OF
MIL-DTL-32139

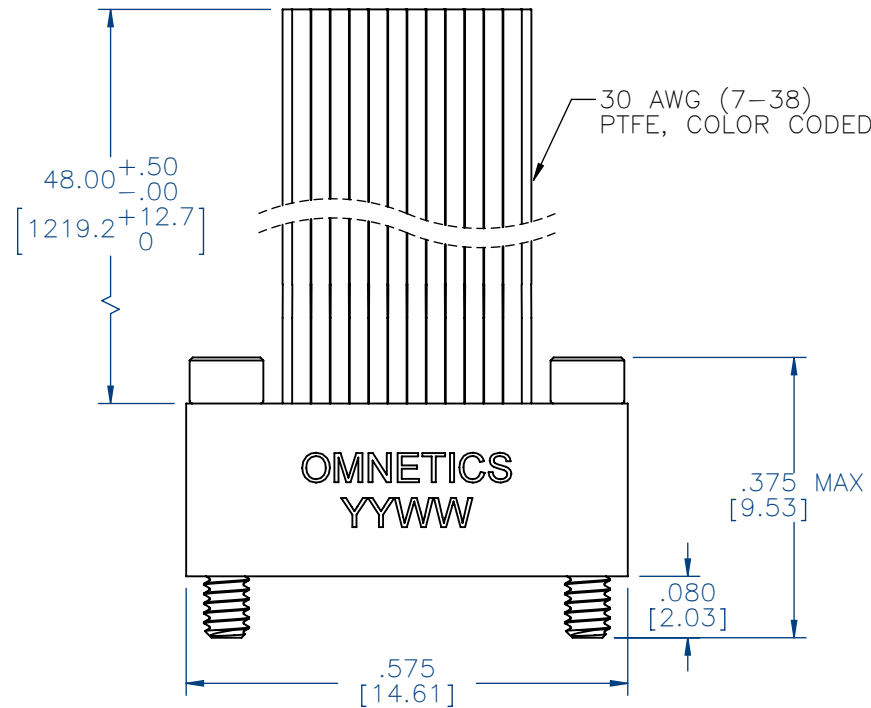

SOCKET #	COLOR
1, 11, 21	BLACK
2, 12, 22	BROWN
3, 13, 23	RED
4, 14, 24	ORANGE
5, 15, 25	YELLOW
6, 16	GREEN
7, 17	BLUE
8, 18	VIOLET
9, 19	GRAY
10, 20	WHITE

INTERNAL USE ONLY
SHEET 2 OF 2 IS A
MFG LOADING DIAGRAM

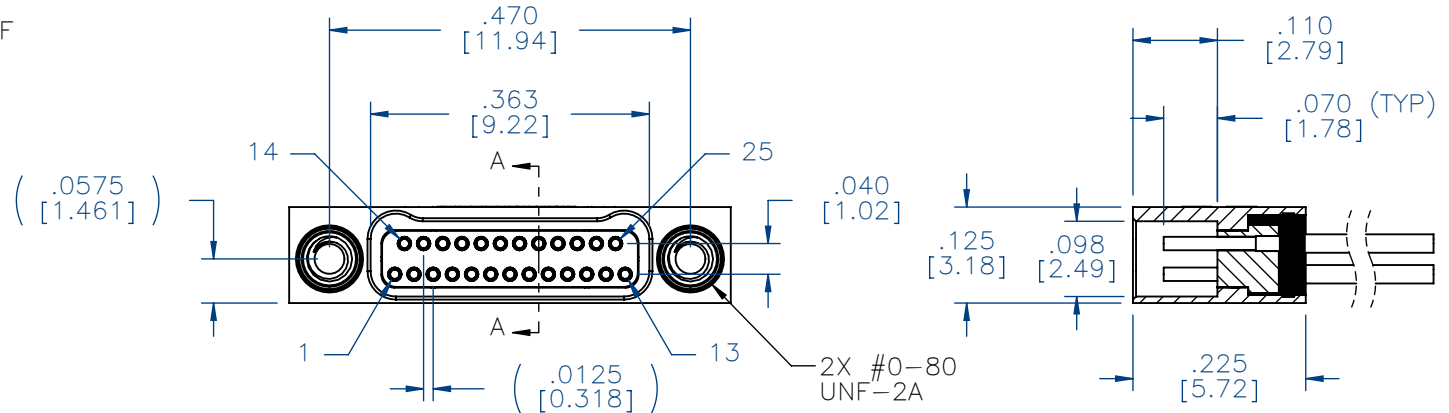
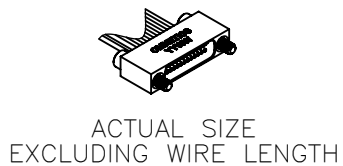

SECTION A-A
VIEW LESS HARDWARE

NOTE:

DIMENSIONS IN [] ARE IN
MILLIMETERS UNLESS
OTHERWISE NOTED AND ARE
FOR REFERENCE ONLY

MGT'S	THIRD ANGLE
	- TOLERANCES - UNLESS OTHERWISE NOTED
OSN/W	DIMENSIONS IN INCHES
	2 PL DEC ± .01
	3 PL DEC ± .005
	4 PL DEC ± .0005
	ANGLES ± 1°

THIS DRAWING CONTAINS CONFIDENTIAL AND PROPRIETARY INFORMATION WHICH IS THE PROPERTY OF OMNETICS CONNECTOR CORP. THIS DOCUMENT MAY NOT, IN WHOLE OR IN PART, BE DUPLICATED, OR DISCLOSED FOR ANY PURPOSE, WITHOUT WRITTEN PERMISSION FROM OMNETICS CONNECTOR CORP.	
DFTM. TLM	DATE 04-13-13
CHK'D.	DATE
APP'D.	DATE
TITLE: (25) SOCKET FEMALE Bi-Lobe® CONNECTOR	

OMNETICS
CONNECTOR CORPORATION
7260 COMMERCE CIRCLE EAST
MINNEAPOLIS, MN 55432
WWW.OMNETICS.COM

CAGE CODE 61873
DWG NO. A29048-125
SHEET 1 OF 2
SCALE: 4:1
REV A

PART NO.	A29048-125	REV	ECO	DATE	APP
		A	99441	04-13-13	TLM

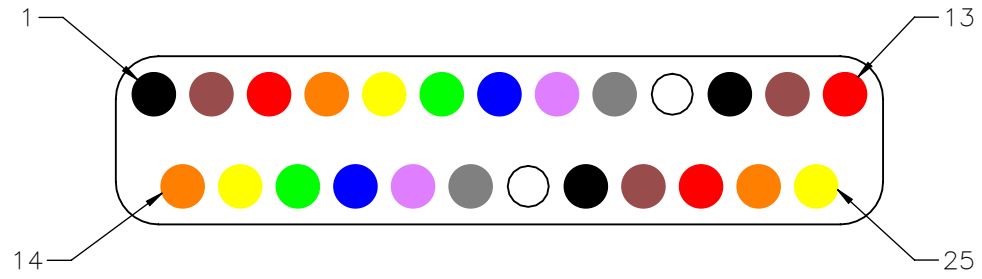

SOCKET #	COLOR
1, 11, 21	BLACK
2, 12, 22	BROWN
3, 13, 23	RED
4, 14, 24	ORANGE
5, 15, 25	YELLOW
6, 16	GREEN
7, 17	BLUE
8, 18	VIOLET
9, 19	GRAY
10, 20	WHITE

MNSO	THIRD ANGLE	THIS DRAWING CONTAINS CONFIDENTIAL AND PROPRIETARY INFORMATION WHICH IS THE PROPERTY OF OMNETICS CONNECTOR CORP. THIS DOCUMENT MAY NOT, IN WHOLE OR IN PART, BE DUPLICATED, OR DISCLOSED FOR ANY PURPOSE, WITHOUT WRITTEN PERMISSION FROM OMNETICS CONNECTOR CORP.	DATE 04-13-13	TITLE: (25) SOCKET FEMALE Bi-Lobe® CONNECTOR	 7260 COMMERCE CIRCLE EAST MINNEAPOLIS, MN 55432 WWW.OMNETICS.COM	CAGE CODE 61873
	—TOLERANCES— UNLESS OTHERWISE NOTED					DFTM. TLM
SLDW	DIMENSIONS IN INCHES	CHK'D.	DATE	APP'D.	DATE	SHEET 2 OF 2
	2 PL DEC ± .01 3 PL DEC ± .005 4 PL DEC ± .0005 ANGLES ± 1°					REV A
						SCALE: 12:1