

PART NO.	A29048-065	REV	ECO	DATE	APP
		A	99440	04-13-13	TLM

MATERIALS & SPECIFICATIONS

- HOUSING:**
ALUMINUM 6061-T6, NICKEL PLATE PER SAE-AMS-2404.
- INSULATOR:**
LIQUID CRYSTAL POLYMER (LCP) PER ASTM D5138
- CONTACT:**
COPPER ALLOY PER MIL-DTL-32139, GOLD PLATED PER ASTM B488, (HARD GOLD) TYPE II CODE C CLASS 1.27
- WIRE:**
NEMA HP3 TYPE ET, COLOR CODED IAW MIL-STD-681, SYSTEM 1, USING TEN SOLID REPEATING COLORS
- CURRENT RATING:**
1 AMP MAX PER MIL-DTL-32139
- CONTACT RESISTANCE:**
71 MILLIOHM MAX (71mV DROP MAX) @ 1.0 AMPS PER MIL-DTL-32139
- PERFORMANCE:**
PRODUCT FAMILY TESTED TO AND PASSED THE PERFORMANCE SPECIFICATIONS OF TABLE VIII OF MIL-DTL-32139.

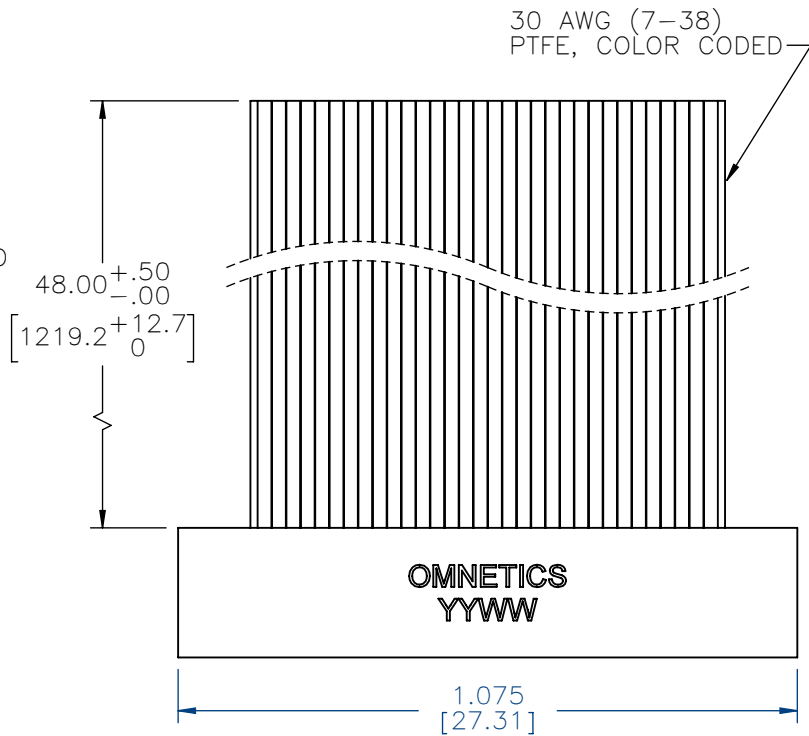

SOCKET #	COLOR
1, 11, 21, 31, 41, 51, 61	BLACK
2, 12, 22, 32, 42, 52, 62	BROWN
3, 13, 23, 33, 43, 53, 63	RED
4, 14, 24, 34, 44, 54, 64	ORANGE
5, 15, 25, 35, 45, 55, 65	YELLOW
6, 16, 26, 36, 46, 56	GREEN
7, 17, 27, 37, 47, 57	BLUE
8, 18, 28, 38, 48, 58	VIOLET
9, 19, 29, 39, 49, 59	GRAY
10, 20, 30, 40, 50, 60	WHITE

INTERNAL USE ONLY
SHEET 2 OF 2 IS A
MFG LOADING DIAGRAM

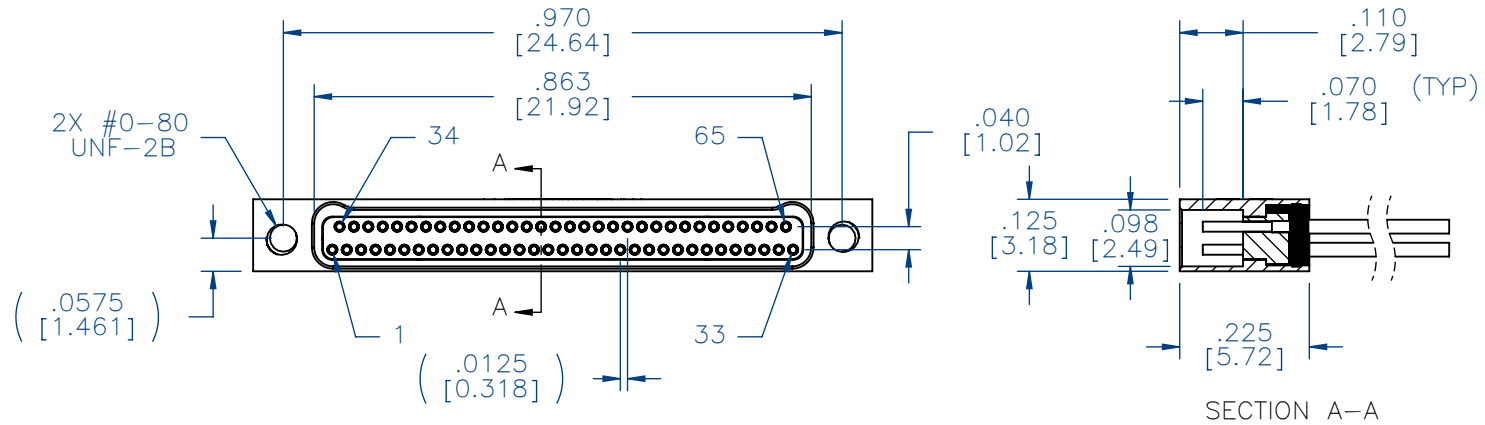
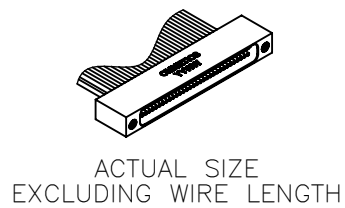

NOTE:
DIMENSIONS IN [] ARE IN MILLIMETERS UNLESS OTHERWISE NOTED AND ARE FOR REFERENCE ONLY

MNSW	THIRD ANGLE
	-TOLERANCES-
	UNLESS OTHERWISE NOTED
	DIMENSIONS IN INCHES
SLDW	2 PL DEC ± .01
	3 PL DEC ± .005
	4 PL DEC ± .0005
	ANGLES ± 1°

THIS DRAWING CONTAINS CONFIDENTIAL AND PROPRIETARY INFORMATION WHICH IS THE PROPERTY OF OMNETICS CONNECTOR CORP. THIS DOCUMENT MAY NOT, IN WHOLE OR IN PART, BE DUPLICATED, OR DISCLOSED FOR ANY PURPOSE, WITHOUT WRITTEN PERMISSION FROM OMNETICS CONNECTOR CORP.	
DFTM. TLM	DATE 04-13-13
CHK'D.	DATE
APP'D.	DATE
TITLE: (65) SOCKET FEMALE Bi-Lobe® CONNECTOR	

OMNETICS
CONNECTOR CORPORATION
7260 COMMERCE CIRCLE EAST
MINNEAPOLIS, MN 55432
WWW.OMNETICS.COM

CAGE CODE 61873
DWG NO. A29048-065
SHEET 1 OF 2
SCALE: 3:1
REV A

PART NO.	A29048-065	REV	ECO	DATE	APP
		A	99440	04-13-13	TLM

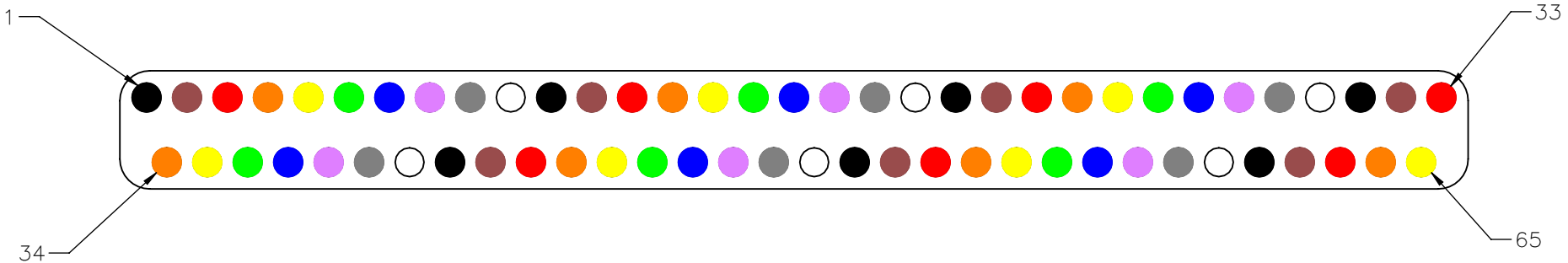

SOCKET #	COLOR
1, 11, 21, 31, 41, 51, 61	BLACK
2, 12, 22, 32, 42, 52, 62	BROWN
3, 13, 23, 33, 43, 53, 63	RED
4, 14, 24, 34, 44, 54, 64	ORANGE
5, 15, 25, 35, 45, 55, 65	YELLOW
6, 16, 26, 36, 46, 56	GREEN
7, 17, 27, 37, 47, 57	BLUE
8, 18, 28, 38, 48, 58	VIOLET
9, 19, 29, 39, 49, 59	GRAY
10, 20, 30, 40, 50, 60	WHITE

MNSW OSNW SLDW	THIRD ANGLE	THIS DRAWING CONTAINS CONFIDENTIAL AND PROPRIETARY INFORMATION WHICH IS THE PROPERTY OF OMNETICS CONNECTOR CORP. THIS DOCUMENT MAY NOT, IN WHOLE OR IN PART, BE DUPLICATED, OR DISCLOSED FOR ANY PURPOSE, WITHOUT WRITTEN PERMISSION FROM OMNETICS CONNECTOR CORP.	DATE 04-13-13 DATE	TITLE: (65) SOCKET FEMALE Bi-Lobe® CONNECTOR	 7260 COMMERCE CIRCLE EAST MINNEAPOLIS, MN 55432 WWW.OMNETICS.COM	CAGE CODE 61873	
	-TOLERANCES-					DWTM. TLM	DWG NO. A29048-065
	UNLESS OTHERWISE NOTED					CHK'D.	SHEET 2 OF 2
	DIMENSIONS IN INCHES					APP'D.	SCALE: 10:1
2 PL DEC± .01		REV					
3 PL DEC± .005		A					
4 PL DEC± .0005							
ANGLES ± 1°							