

PART NO.	A29036-065	REV	ECO	DATE	APP
		A	98850	09-05-12	TLM

MATERIALS & SPECIFICATIONS

HOUSING:
ALUMINUM 60601-T6,
NICKEL PLATE PER
SAE-AMS-2404.

INSULATOR:
LIQUID CRYSTAL
POLYMER (LCP) PER
ASTM D5138

CONTACT:
COPPER ALLOY PER
MIL-DTL-32139, GOLD
PLATED PER ASTM
B488, (HARD GOLD)
TYPE II CODE C
CLASS 1.27

WIRE:
NEMA HP3 TYPE ET,
COLOR CODED IAW
MIL-STD-681, SYSTEM
1, USING TEN SOLID
REPEATING COLORS

CURRENT RATING:
1 AMP MAX PER MIL-
DTL-32139

CONTACT RESISTANCE:
71 MILLIOHM MAX
(71mV DROP MAX) @
1.0 AMPS PER MIL-
DTL-32139

PERFORMANCE:
PRODUCT FAMILY
TESTED TO AND
PASSED THE
PERFORMANCE
SPECIFICATIONS OF
TABLE VIII OF MIL-
DTL-32139.

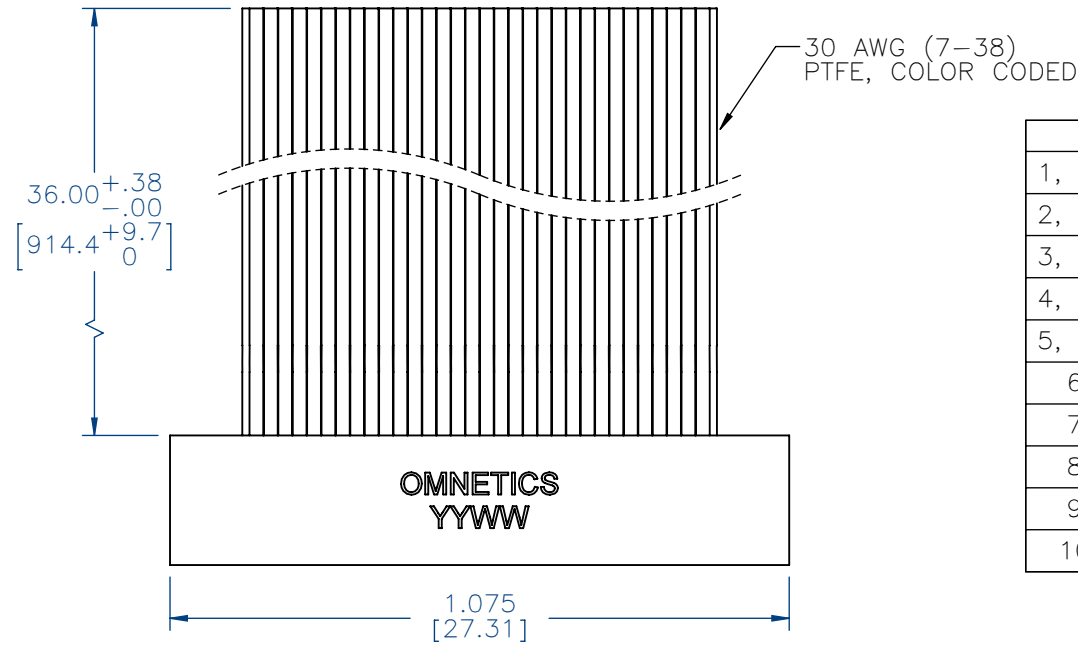

SOCKET #	COLOR
1, 11, 21, 31, 41, 51, 61	BLACK
2, 12, 22, 32, 42, 52, 62	BROWN
3, 13, 23, 33, 43, 53, 63	RED
4, 14, 24, 34, 44, 54, 64	ORANGE
5, 15, 25, 35, 45, 55, 65	YELLOW
6, 16, 26, 36, 46, 56	GREEN
7, 17, 27, 37, 47, 57	BLUE
8, 18, 28, 38, 48, 58	VIOLET
9, 19, 29, 39, 49, 59	GRAY
10, 20, 30, 40, 50, 60	WHITE

INTERNAL USE ONLY
SHEET 2 OF 2 IS A
MFG LOADING DIAGRAM

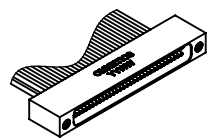
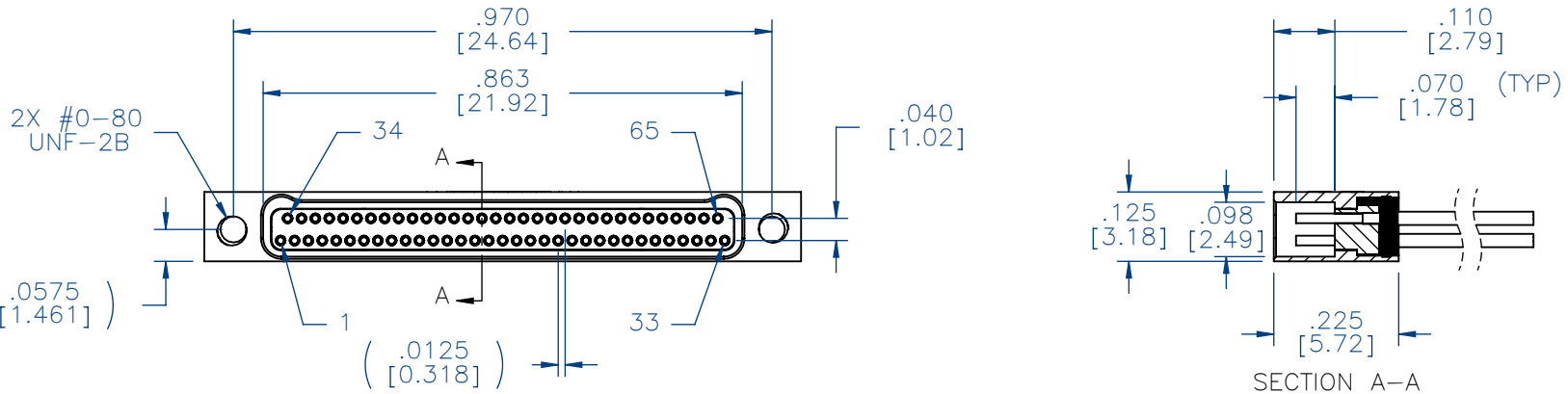

ACTUAL SIZE
EXCLUDING WIRE LENGTH

MNSW	THIRD ANGLE
	-TOLERANCES-
	UNLESS OTHERWISE NOTED
	DIMENSIONS IN INCHES
MLTS	2 PL DEC ± .01
	3 PL DEC ± .005
	4 PL DEC ± .0005
	ANGLES ± 1°

THIS DRAWING CONTAINS CONFIDENTIAL AND PROPRIETARY INFORMATION WHICH IS THE PROPERTY OF OMNETICS CONNECTOR CORP. THIS DOCUMENT MAY NOT, IN WHOLE OR IN PART, BE DUPLICATED, OR DISCLOSED FOR ANY PURPOSE, WITHOUT WRITTEN PERMISSION FROM OMNETICS CONNECTOR CORP.

DFTM. TLM DATE 07-31-12 TITLE: (65) SOCKET FEMALE
CHK'D. DATE Bi-Lobe® CONNECTOR
APP'D. DATE

OMNETICS
CONNECTOR CORPORATION
7260 COMMERCE CIRCLE EAST
MINNEAPOLIS, MN 55432
WWW.OMNETICS.COM

CAGE CODE	61873
DWG NO.	A29036-065
SHEET 1 OF 2	REV A
SCALE:	3:1

PART NO.	A29036-065	REV	ECO	DATE	APP
		A	98850	09-05-12	TLM

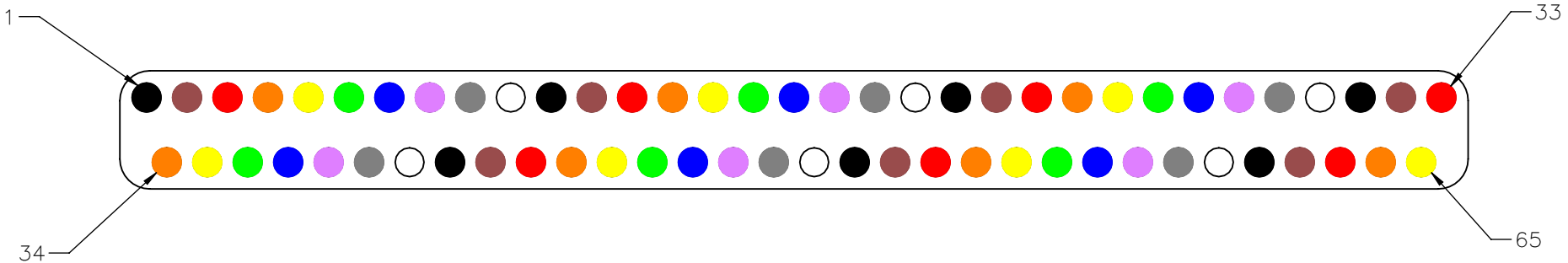

SOCKET #	COLOR
1, 11, 21, 31, 41, 51, 61	BLACK
2, 12, 22, 32, 42, 52, 62	BROWN
3, 13, 23, 33, 43, 53, 63	RED
4, 14, 24, 34, 44, 54, 64	ORANGE
5, 15, 25, 35, 45, 55, 65	YELLOW
6, 16, 26, 36, 46, 56	GREEN
7, 17, 27, 37, 47, 57	BLUE
8, 18, 28, 38, 48, 58	VIOLET
9, 19, 29, 39, 49, 59	GRAY
10, 20, 30, 40, 50, 60	WHITE

MNSW OSNW SLDW	THIRD ANGLE	THIS DRAWING CONTAINS CONFIDENTIAL AND PROPRIETARY INFORMATION WHICH IS THE PROPERTY OF OMNETICS CONNECTOR CORP. THIS DOCUMENT MAY NOT, IN WHOLE OR IN PART, BE DUPLICATED, OR DISCLOSED FOR ANY PURPOSE, WITHOUT WRITTEN PERMISSION FROM OMNETICS CONNECTOR CORP.	DATE 07-31-12	TITLE: (65) SOCKET FEMALE Bi-Lobe® CONNECTOR	 7260 COMMERCE CIRCLE EAST MINNEAPOLIS, MN 55432 WWW.OMNETICS.COM	CAGE CODE 61873
	-TOLERANCES-					DWG NO. A29036-065
	UNLESS OTHERWISE NOTED					SHEET 2 OF 2
	DIMENSIONS IN INCHES					REV A
2 PL DEC± .01	DFTM. TLM	DATE	DATE			SCALE: 10:1
3 PL DEC± .005	CHK'D.	DATE				
4 PL DEC± .0005	APP'D.	DATE				
ANGLES ± 1°						