

MATERIALS & SPECIFICATIONS

PART NO.	A29000-115	REV	ECO	DATE	APP
		G	96258	10-19-09	TLM

- HOUSING:**
ALUMINUM 6061-T6, NICKEL PLATE
PER AMS-C-26074
- INSULATOR:**
LIQUID CRYSTAL POLYMER (LCP) PER
ASTM D5138
- CONTACT:**
COPPER ALLOY PER MIL-DTL-32139,
GOLD PLATED PER ASTM B488,
(HARD GOLD) TYPE II CODE C CLASS
1.27
- WIRE:**
NEMA HP3 TYPE ET, COLOR CODED
IAW MIL-STD-681, SYSTEM 1, USING
TEN SOLID REPEATING COLORS
- HARDWARE:**
303 STAINLESS STEEL PER ASTM 582
- CURRENT RATING:**
1 AMP MAX PER MIL-DTL-32139
- CONTACT RESISTANCE:**
71 MILLIOHM MAX (71mV DROP MAX)
@ 1.0 AMPS PER MIL-DTL-32139
- PERFORMANCE:**
PRODUCT FAMILY TESTED TO AND
PASSED THE PERFORMANCE
SPECIFICATIONS OF TABLE VIII OF
MIL-DTL-32139

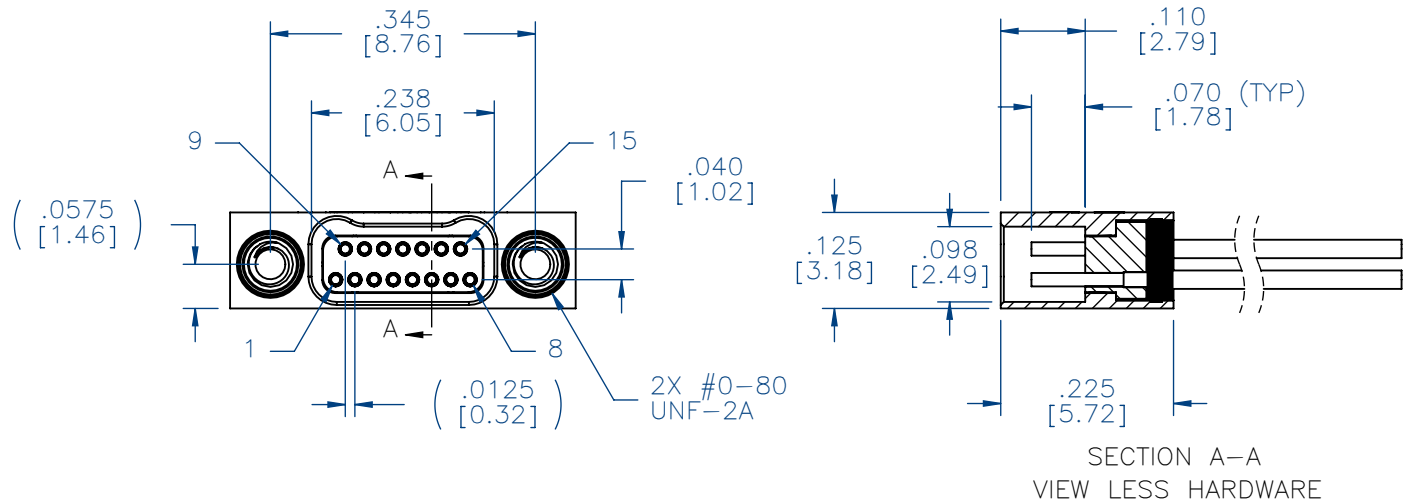
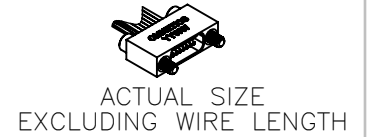
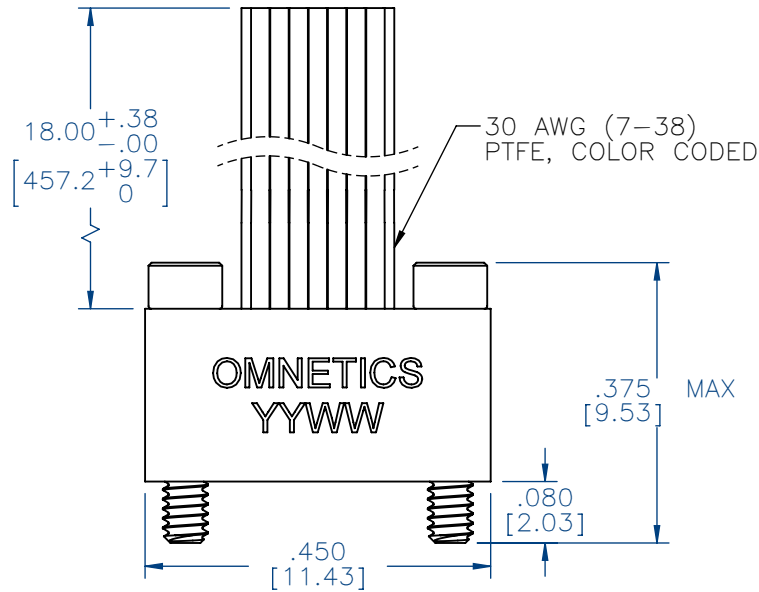

INTERNAL USE ONLY

SHEET 2 OF 2 IS A
MFG LOADING DIAGRAM

SOCKET #	COLOR
1, 11	BLACK
2, 12	BROWN
3, 13	RED
4, 14	ORANGE
5, 15	YELLOW
6	GREEN
7	BLUE
8	VIOLET
9	GRAY
10	WHITE

MNSO	THIRD ANGLE
	-TOLERANCES-
MCTD	UNLESS OTHERWISE NOTED
	DIMENSIONS IN INCHES
	2 PL DEC ± .01
	3 PL DEC ± .005
	4 PL DEC ± .0005
	ANGLES ± 1°

THIS DRAWING CONTAINS CONFIDENTIAL AND PROPRIETARY INFORMATION WHICH IS THE PROPERTY OF OMNETICS CONNECTOR CORP. THIS DOCUMENT MAY NOT, IN WHOLE OR IN PART, BE DUPLICATED, OR DISCLOSED FOR ANY PURPOSE, WITHOUT WRITTEN PERMISSION FROM OMNETICS CONNECTOR CORP.	
DFTM. AAS	DATE 05-10-04
CHK'D.	DATE
APP'D.	DATE
TITLE: (15) SOCKET FEMALE BI-LOBE CONNECTOR	

OMNETICS
CONNECTOR CORPORATION
7260 COMMERCE CIRCLE EAST
MINNEAPOLIS, MN 55432
WWW.OMNETICS.COM

CAGE CODE	61873
DWG NO.	A29000-115
SHEET 1 OF 2	REV G
SCALE:	4:1

PART NO.	A29000-115	REV	ECO	DATE	APP
		G	96258	10-19-09	TLM

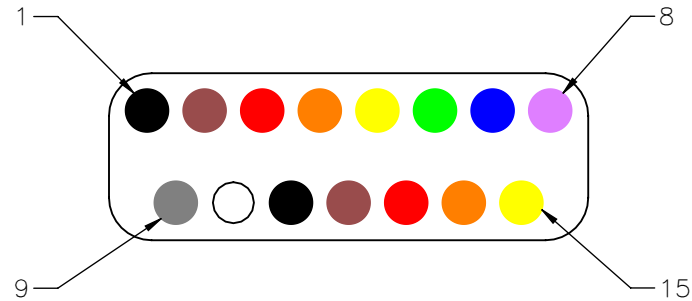

SOCKET #	COLOR
1, 11	BLACK
2, 12	BROWN
3, 13	RED
4, 14	ORANGE
5, 15	YELLOW
6	GREEN
7	BLUE
8	VIOLET
9	GRAY
10	WHITE

MNSO SLDW	THIRD ANGLE
	-TOLERANCES-
	UNLESS OTHERWISE NOTED
	DIMENSIONS IN INCHES
2 PL DEC ± .01	
3 PL DEC ± .005	
4 PL DEC ± .0005	
ANGLES ± 1°	

THIS DRAWING CONTAINS CONFIDENTIAL AND PROPRIETARY INFORMATION WHICH IS THE PROPERTY OF OMNETICS CONNECTOR CORP. THIS DOCUMENT MAY NOT, IN WHOLE OR IN PART, BE DUPLICATED, OR DISCLOSED FOR ANY PURPOSE, WITHOUT WRITTEN PERMISSION FROM OMNETICS CONNECTOR CORP.	
DFTM. AAS	DATE 05-10-04
CHK'D.	DATE
APP'D.	DATE

TITLE:
(15) SOCKET FEMALE
BI-LOBE CONNECTOR
-

OMNETICS
CONNECTOR CORPORATION
7260 COMMERCE CIRCLE EAST
MINNEAPOLIS, MN 55432
WWW.OMNETICS.COM

CAGE CODE 61873	REV
DWG NO. A29000-115	G
SHEET 2 OF 2	SCALE: 12:1