

MATERIALS & SPECIFICATIONS

PART NO.	A29000-031	REV	ECO	DATE	APP
		G	96257	10-19-09	TLM

HOUSING:
ALUMINUM 60601-T6, NICKEL PLATE
PER AMS-C-26074.

INSULATOR:
LIQUID CRYSTAL POLYMER (LCP) PER
ASTM D5138

CONTACT:
COPPER ALLOY PER MIL-DTL-32139,
GOLD PLATED PER ASTM B488, (HARD
GOLD) TYPE II CODE C CLASS 1.27

WIRE:
NEMA HP3 TYPE ET, COLOR CODED
IAW MIL-STD-681, SYSTEM 1, USING
TEN SOLID REPEATING COLORS

CURRENT RATING:
1 AMP MAX PER MIL-DTL-32139

CONTACT RESISTANCE:
71 MILLIOHM MAX (71mV DROP MAX)
@ 1.0 AMPS PER MIL-DTL-32139

PERFORMANCE:
PRODUCT FAMILY TESTED TO AND
PASSED THE PERFORMANCE
SPECIFICATIONS OF TABLE VIII OF
MIL-DTL-32139.

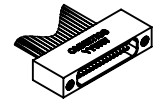
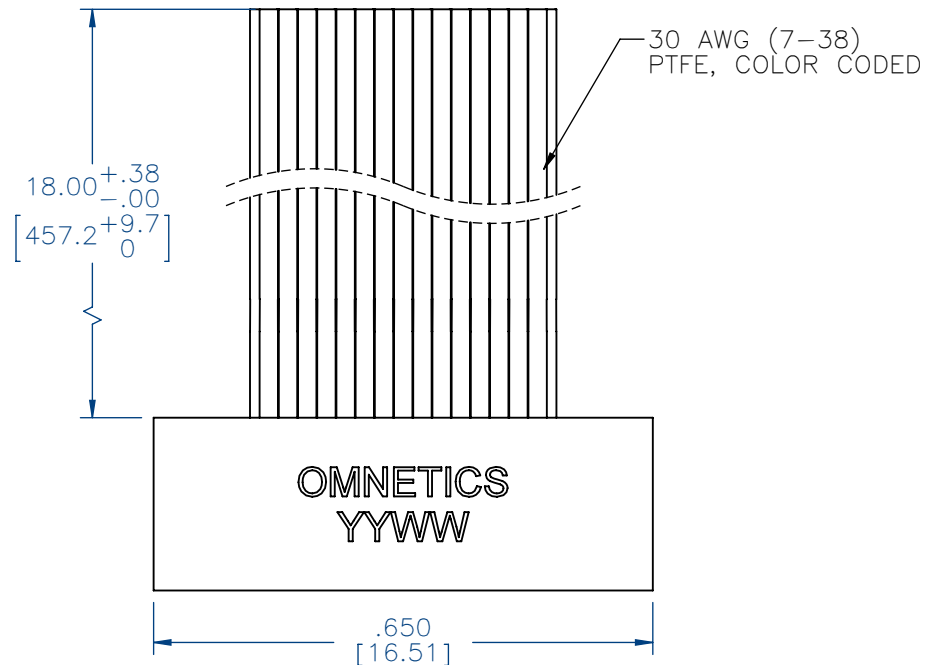

ACTUAL SIZE
EXCLUDING WIRE LENGTH

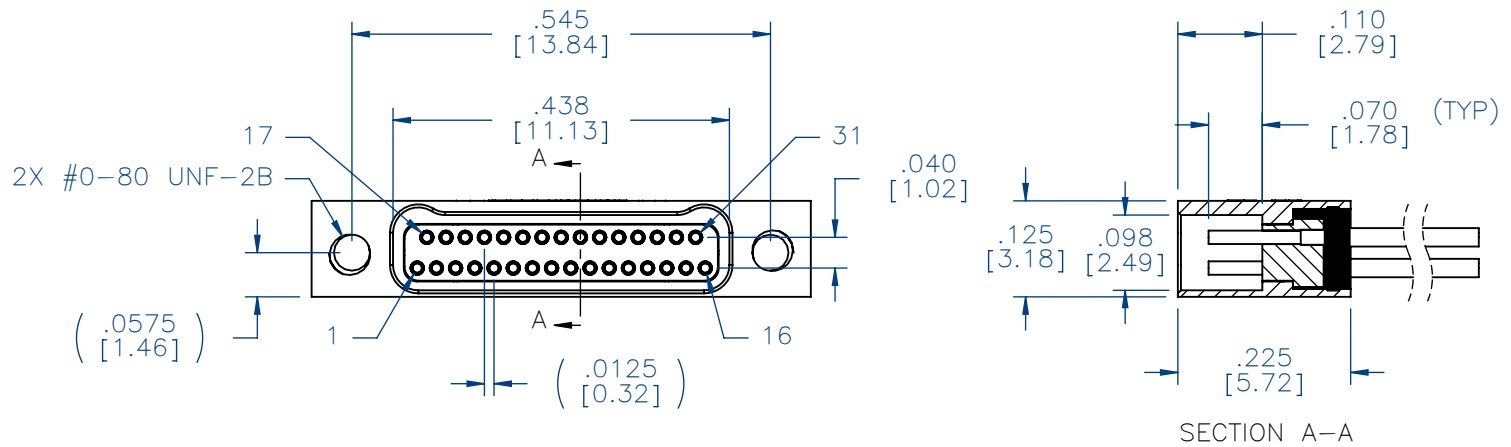

INTERNAL USE ONLY

SHEET 2 OF 2 IS A
MFG LOADING DIAGRAM

SOCKET #	COLOR
1, 11, 21, 31	BLACK
2, 12, 22	BROWN
3, 13, 23	RED
4, 14, 24	ORANGE
5, 15, 25	YELLOW
6, 16, 26	GREEN
7, 17, 27	BLUE
8, 18, 28	VIOLET
9, 19, 29	GRAY
10, 20, 30	WHITE

MNSO SIDW	THIRD ANGLE
	-TOLERANCES-
	UNLESS OTHERWISE NOTED
	DIMENSIONS IN INCHES
	2 PL DEC ± .01 3 PL DEC ± .005 4 PL DEC ± .0005 ANGLES ± 1°

THIS DRAWING CONTAINS CONFIDENTIAL AND PROPRIETARY INFORMATION WHICH IS THE PROPERTY OF OMNETICS CONNECTOR CORP. THIS DOCUMENT MAY NOT, IN WHOLE OR IN PART, BE DUPLICATED, OR DISCLOSED FOR ANY PURPOSE, WITHOUT WRITTEN PERMISSION FROM OMNETICS CONNECTOR CORP.

DFTM. AAS DATE 05-07-04 TITLE: (31) SOCKET FEMALE BI-LOBE CONNECTOR

CHK'D. DATE

APP'D. DATE

OMNETICS
CONNECTOR CORPORATION

7260 COMMERCE CIRCLE EAST
MINNEAPOLIS, MN 55432
WWW.OMNETICS.COM

CAGE CODE 61873
DWG NO. A29000-031
SHEET 1 OF 2
SCALE: 4:1
REV G

PART NO.	A29000-031	REV	ECO	DATE	APP
		G	96257	10-19-09	TLM

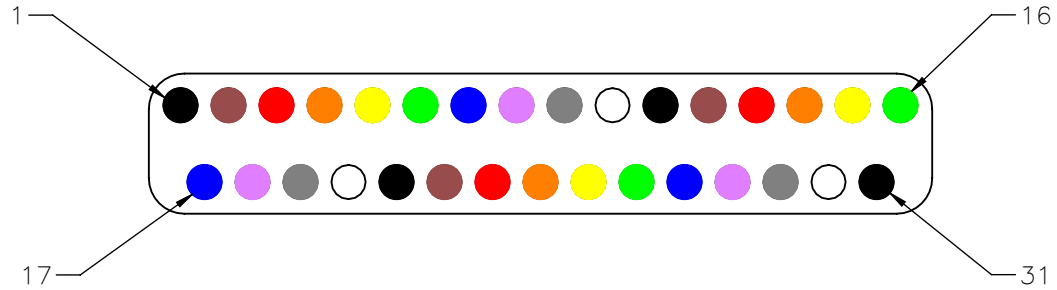

SOCKET #	COLOR
1, 11, 21, 31	BLACK
2, 12, 22	BROWN
3, 13, 23	RED
4, 14, 24	ORANGE
5, 15, 25	YELLOW
6, 16, 26	GREEN
7, 17, 27	BLUE
8, 18, 28	VIOLET
9, 19, 29	GRAY
10, 20, 30	WHITE

MNSO SLDW	THIRD ANGLE	THIS DRAWING CONTAINS CONFIDENTIAL AND PROPRIETARY INFORMATION WHICH IS THE PROPERTY OF OMNETICS CONNECTOR CORP. THIS DOCUMENT MAY NOT, IN WHOLE OR IN PART, BE DUPLICATED, OR DISCLOSED FOR ANY PURPOSE, WITHOUT WRITTEN PERMISSION FROM OMNETICS CONNECTOR CORP.	<p>OMNETICS CONNECTOR CORPORATION</p> <p>7260 COMMERCE CIRCLE EAST MINNEAPOLIS, MN 55432 WWW.OMNETICS.COM</p>	CAGE CODE 61873
	UNLESS OTHERWISE NOTED DIMENSIONS IN INCHES			DWG NO. A29000-031
2 PL DEC ± .01	DFTM. AAS DATE 05-07-04	TITLE: (31) SOCKET FEMALE BI-LOBE CONNECTOR	7260 COMMERCE CIRCLE EAST MINNEAPOLIS, MN 55432 WWW.OMNETICS.COM	SHEET 2 OF 2
3 PL DEC ± .005	CHK'D.			REV G
4 PL DEC ± .0005	APP'D.			SCALE: 10:1
ANGLES ± 1°				