

MATERIALS & SPECIFICATIONS

PART NO.	A28500-025	REV	ECO	DATE	APP
		J	109938	05-09-23	BAS

HOUSING:
ALUMINUM 6061, NICKEL PLATED
(500 MICROINCHES MINIMUM) PER
SAE-AMS-2404

INSULATOR:
LIQUID CRYSTAL POLYMER (LCP)
PER ASTM D5138

CONTACT:
BERYLLIUM COPPER PER ASTM
B194, C17200, GOLD PLATED
PER ASTM B488, (HARD GOLD)
TYPE II CODE C, CLASS 1.27

TERMINATION:
SOLDER COATED WITH SN63A PER
J-STD-006 OR AMS-P-81728

HARDWARE:
303 STAINLESS STEEL PER
ASTM A582

CURRENT RATING:
1 AMP MAX PER MIL-DTL-32139

CONTACT RESISTANCE:
71 MILLIOHM MAX (71mV DROP
MAX) @ 1.0 AMPS PER MIL-
DTL-32139

PERFORMANCE:
PRODUCT FAMILY TESTED TO AND
PASSED THE PERFORMANCE
SPECIFICATIONS OF TABLE VIII OF
MIL-DTL-32139

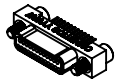
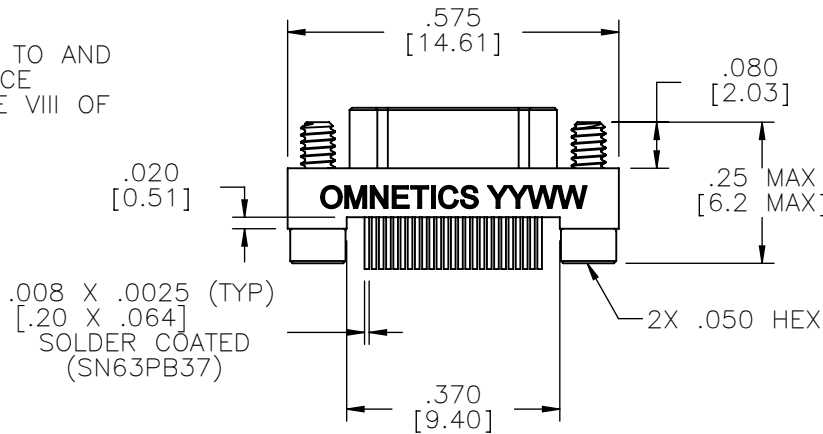
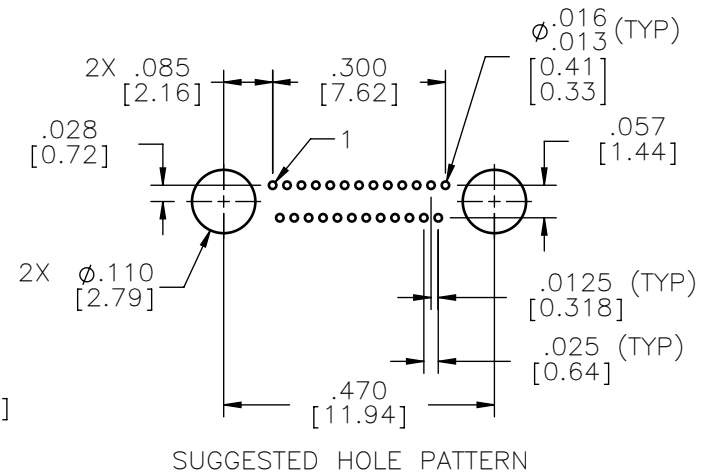
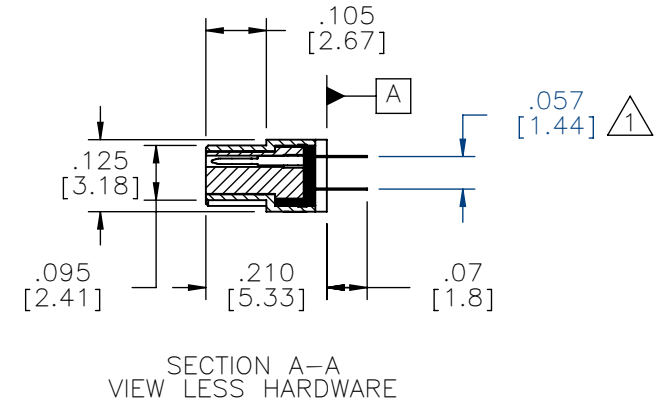
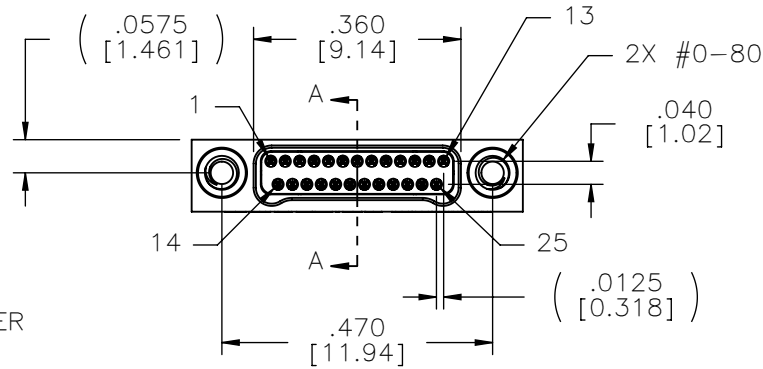

ACTUAL SIZE

NOTES:

1. TAIL DIMENSIONS APPLY AT PLANE A

2. DIMENSIONS IN [] ARE IN MILLIMETERS UNLESS OTHERWISE NOTED AND ARE FOR REFERENCE ONLY.

MFG	THIRD ANGLE	THIS DRAWING CONTAINS CONFIDENTIAL AND PROPRIETARY INFORMATION WHICH IS THE PROPERTY OF OMNETICS CONNECTOR CORP. THIS DOCUMENT MAY NOT, IN WHOLE OR IN PART, BE DUPLICATED, OR DISCLOSED FOR ANY PURPOSE, WITHOUT WRITTEN PERMISSION FROM OMNETICS CONNECTOR CORP.
	-TOLERANCES-	
SLDW	UNLESS OTHERWISE NOTED	TITLE:
	DIMENSIONS IN INCHES	(25) PIN MALE
	2 PL DEC ± .01	DFTM. AAS
	3 PL DEC ± .005	DATE
	4 PL DEC ± .0005	05-05-04
	ANGLES ± 1°	BI-LOBE® CONNECTOR

OMNETICS
CONNECTOR CORPORATION
8840 EVERGREEN BLVD.
MINNEAPOLIS, MN 55433
WWW.OMNETICS.COM

DWG NO.	CAGE CODE	61873
		A28500-025
SHEET	SCALE:	REV
1 OF 1	3:1	J