

# MATERIALS & SPECIFICATIONS

PART NO.	A28072-031	REV	ECO	DATE	APP
		A	107647	11-09-21	BAS

**HOUSING:**  
ALUMINUM 6061, NICKEL PLATE (500 MICRONS MINIMUM) PER SAE-AMS-2404

**INSULATOR:**  
LIQUID CRYSTAL POLYMER (LCP) PER ASTM D5138

**CONTACT:**  
BERYLLIUM COPPER PER ASTM B194, C17200, GOLD PLATED PER ASTM B488, (HARD GOLD) TYPE II CODE C, CLASS 1.27

**WIRE:**  
NEMA HP3 TYPE ET, COLOR CODED IAW MIL-STD-681, SYSTEM 1, USING TEN SOLID REPEATING COLORS

**HARDWARE:**  
303 STAINLESS STEEL PER ASTM A582

**CURRENT RATING:**  
1 AMP MAX PER MIL-DTL-32139

**CONTACT RESISTANCE:**  
71 MILLIOHM MAX (71mV DROP MAX) @ 1.0 AMPS PER MIL-DTL-32139

**PERFORMANCE:**  
PRODUCT FAMILY TESTED TO AND PASSED THE PERFORMANCE SPECIFICATIONS OF TABLE VIII OF MIL-DTL-32139

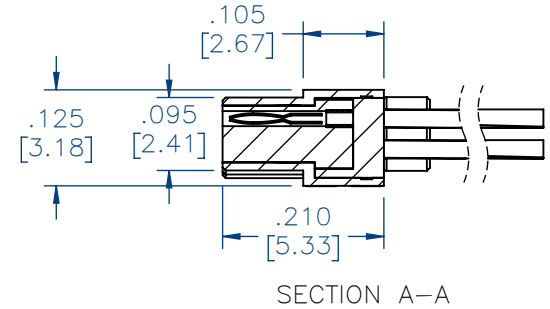
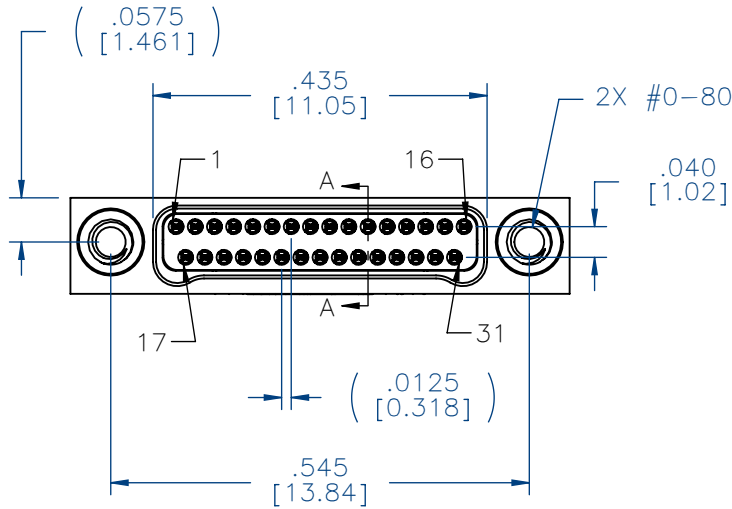

PIN #	COLOR
1, 11, 21, 31	BLACK
2, 12, 22	BROWN
3, 13, 23	RED
4, 14, 24	ORANGE
5, 15, 25	YELLOW
6, 16, 26	GREEN
7, 17, 27	BLUE
8, 18, 28	VIOLET
9, 19, 29	GRAY
10, 20, 30	WHITE

INTERNAL USE ONLY  
USE MFG LOADING  
PROCEDURE A28000-031

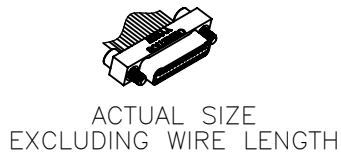
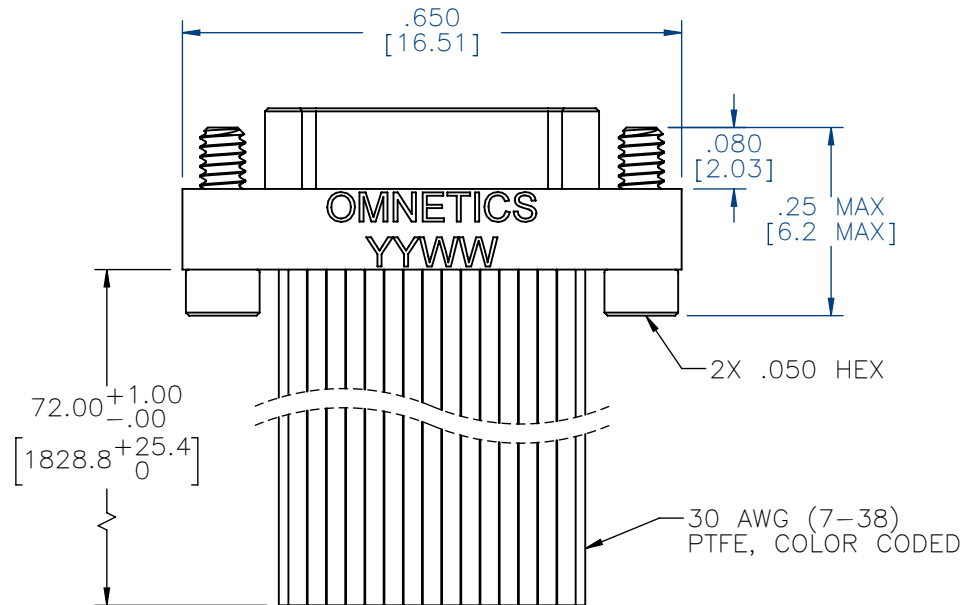

**NOTE:**

DIMENSIONS IN [ ] ARE IN MILLIMETERS UNLESS OTHERWISE NOTED AND ARE FOR REFERENCE ONLY

M/PO	THIRD ANGLE
	-TOLERANCES-
SLDW	UNLESS OTHERWISE NOTED
	DIMENSIONS IN INCHES
	2 PL DEC ± .01
	3 PL DEC ± .005
	4 PL DEC ± .0005
	ANGLES ± 1°

THIS DRAWING CONTAINS CONFIDENTIAL AND PROPRIETARY INFORMATION WHICH IS THE PROPERTY OF OMNETICS CONNECTOR CORP. THIS DOCUMENT MAY NOT, IN WHOLE OR IN PART, BE DUPLICATED, OR DISCLOSED FOR ANY PURPOSE, WITHOUT WRITTEN PERMISSION FROM OMNETICS CONNECTOR CORP.	
TITLE:	(31) PIN MALE
DFTM. DWP	BI-LOBE® CONNECTOR
DATE	10-05-21

**OMNETICS**  
CONNECTOR CORPORATION  
7260 COMMERCE CIRCLE EAST  
MINNEAPOLIS, MN 55432  
WWW.OMNETICS.COM

DWG NO.	CAGE CODE	61873
		A28072-031
SHEET	SCALE:	REV
1 OF 1	4:1	A